



Type(s)  
Project  
Date  
Notes

**GENERAL INFORMATION**

ETC’s Desire Series D60XTI brings the amazing control of the x7 Color System and the long throw of a D60 to your facility for permanent installation. With its IP66 rating, this luminaire is ready for mounting inside or outside—wherever you need it. The x7 Color System produces the widest range of spectrally-balanced saturated and tinted color choices available. The D60XTI offers a rugged die-cast enclosure, noiseless fan-free operation and multiple lens options that can be changed on site.

**D60XTI LED ARRAY OPTIONS**

D60XTI luminaires are based on the x7 color system that uses seven different LED colors to achieve true, usable broad spectrum color. The D60XTI luminaire is available with any one of the following x7 color arrays to best suit the intended application:

- D60XTI Vivid – the x7 color system array balanced for best all-around use as a color-changing wash luminaire.
- D60XTI Lustr+ – optimized with six colors plus high-intensity white LEDs to create an ideal frontlight wash fixture. Full range color, with an emphasis on lighter colors and white.
- D60XTI Studio HD – Studio HD combines warm white and cool white LEDs for variable color temperature mixing. Added to this are five carefully chosen LED colors from the Selador x7 color system to fill in the white LED spectral gaps. D60XTI Studio HD provides the richest variable white light possible in an LED luminaire.

Also available in the following static white arrays:

- D60XTI Studio Daylight – Studio Daylight contains sixty 5600 K LEDs for high-intensity, non-variable cool-white output
- D60XTI Studio Tungsten – Studio Tungsten contains sixty 3000 K LEDs for high-intensity, non-variable warm-white output

**ORDERING INFORMATION**

**Selador D60XTI**

MODEL	DESCRIPTION	ETL PART NUMBER	CE PART NUMBER	
SELD60XTI-V	D60XTI Vivid wash luminaire	7410A1201	7410A1201-0X	
SELD60XTI-L	D60XTI Lustr+ front-light wash luminaire	7410A1205	7410A1205-0X	
SELD60XTI-H	D60XTI Studio HD wash luminaire	7410A1202	7410A1202-0X	
SELD60XTI-D	D60XTI Studio Daylight wash luminaire	7410A1207	7410A1207-0X	
SELD60XTI-T	D60XTI Studio Tungsten wash luminaire	7410A1206	7410A1206-0X	

Color options: -1 / -1X = white, -5 / -5X = silver gray/custom colors

Note: D60XTI luminaires ship with a hanging yoke, attached leads and a data termination board. C-clamp, lenses and other accessories are not included.



## PRODUCT SPECIFICATIONS

## Source

LED details	60 Lumileds LUXEON® Rebel LED
Max lumens	Vivid: 3,760 Lustr+: 4,317 Studio HD: 4,532 Studio Daylight: 8,216 Studio Tungsten: 6,482
Lumens per watt	Vivid: 31.9 Lustr+: 34.9 Studio HD: 33.4 Studio Daylight: 55.3 Studio Tungsten: 43.2
L70 rating (hours to 70% output)	50,000 hours

## Color

Colors used	Lustr+: Red, Amber, Green, Cyan, Blue, Indigo, White Vivid: Red, Red-Orange, Amber, Green, Cyan, Blue, Indigo Studio HD: Red, Amber, Green/Cyan, Blue, Warm White, Cool White Studio Daylight: White Studio Tungsten: White
Color temperature range	2,700–6,500 K
Calibrated array	Vivid: Yes Lustr+: Yes Studio HD: Yes Studio Daylight: No Studio Tungsten: No
Red shift	Yes (not available on static white)

## Optical

Beam angle range	8°–17°
Aperture size	9 in
Pattern projection	No
Pattern size	N/A
Camera flicker control/Hz range	Yes: 900–25,000 Hz
Notes	Secondary lenses available for multiple beam-spread options

## Control

Input method	DMX512 via termination board
Protocols	DMX512/RDM
Modes (footprint)	See page 6
RDM configuration	Yes
UI type	None (configure via RDM)
Local control	No
Onboard presets	Yes
Onboard sequences	No
Onboard effects	No

## Control

Fixture-to-fixture control	No
Notes	15-bit virtual dimming engine

## Electrical

Voltage range	100–240 VAC 50/60 Hz
Input method	Waterproof, 72" outdoor power lead Requires power from non-dim source
Inrush	46 A at 120 V (First half-cycle) 77 A at 240 V (First half-cycle)
Fixtures per circuit*	10 (15 A may be fed on same circuit)
Wattage typical	124
Current draw	1 A

\*All measurements are for 120 V, 60 Hz. Results may vary in different regions.

## Thermal

Ambient operating temp	-20°C to 40°C (-4°F to 104°F)
Fan (controllable)	No
Droop compensation	Yes
dB range	N/A
BTUs/hour	423.088

## Physical

Materials	Die-cast, all metal housing
Color options	Black, white, silver, or custom color
Mounting options	Single-pole mount, wall or square pole mount, twin fixture pole mount
IP rating	IP66 for exterior wet-location
Weight	10.5 kg (23 lb)
Included accessories	Hanging yoke, data termination board, accessory ring for installations of secondary lenses
Notes	- Cable diameter: power 0.53 in - Effective projected area (EPA): 0.95

## Warranty

Fixture	5 years
LED array	10 years

## Regulatory and Compliance

Approved regulatory standards	cETLus Listed Conforms to UL1598 Certified to CSA C22.2 No. 250.0 CE Compliant
-------------------------------	---

ETC utilizes a nationally recognized 3rd party lab for luminaire testing according to IES LM-84. See [etconnect.com/About/News/ETC-Fixture-Ratings-and-Warranties-Extended.aspx](http://etconnect.com/About/News/ETC-Fixture-Ratings-and-Warranties-Extended.aspx).

All LED sources experience some lessening of light output and some color shift over time. LED output will vary with thermal conditions. In individual situations, LEDs will be used for different durations and levels. This can eventually lead to minor alterations in color performance, necessitating slight adjustments to presets, cues or programs.

PRODUCT FEATURES



**INDUSTRY LEADING WARRANTY**

Five year warranty on the full fixture and a ten year warranty on the LED array.



**EXCLUSIVE X7 COLOR SYSTEM**

Provides a full gamut of color options for every design.

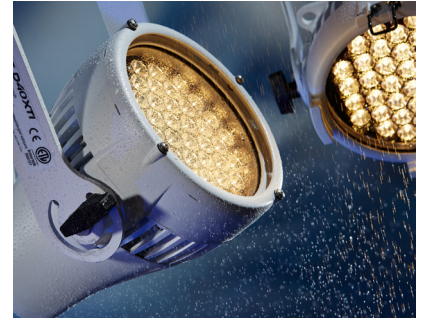

**WATERPROOF OUTDOOR-RATED POWER LEAD**

Rugged, durable fixture ETL 1598-rated for permanent indoor use and IP66-rated for long-term outdoor use.

COLOR METRIC INFORMATION

DESIRE D60XTI LUSTR+ 3200 K TM-30-18

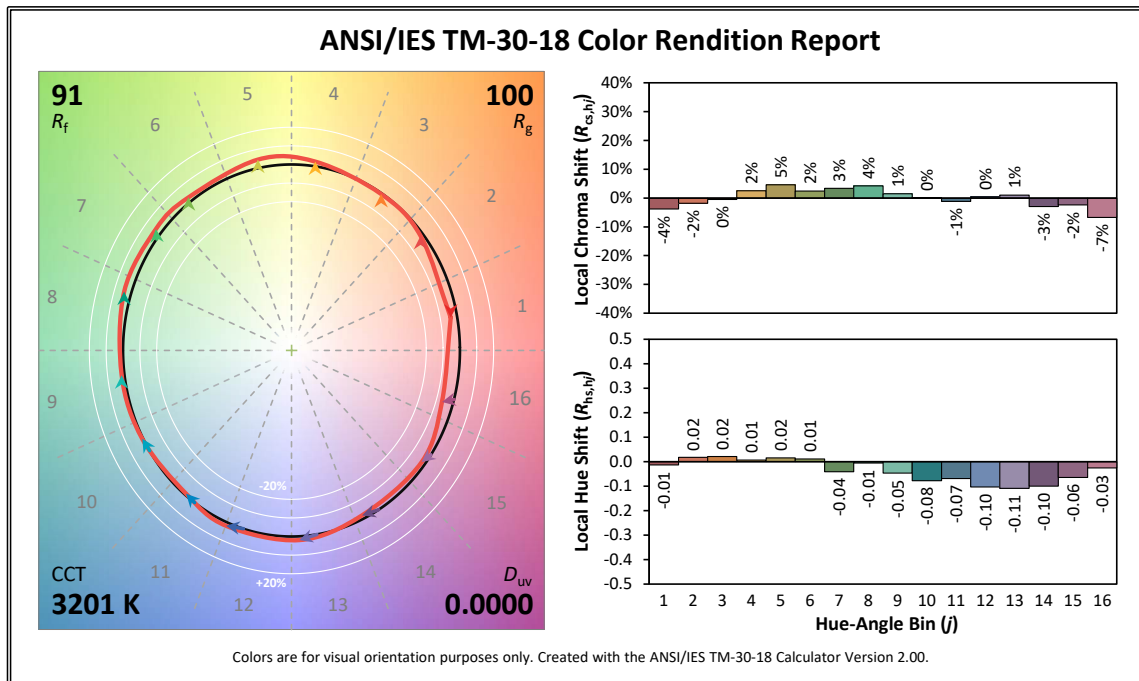

COLOR METRIC INFORMATION

DESIRE D60XTI LUSTR+ 5600 K TM-30-18

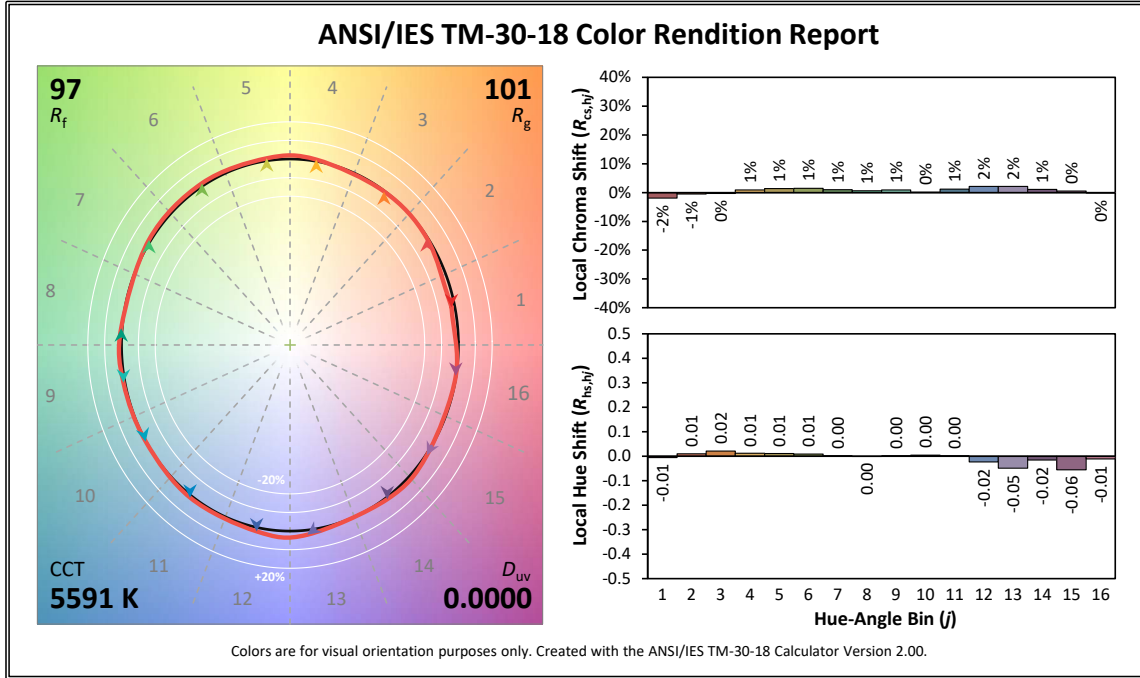

DESIRE D60XTI VIVID 3200 K TM-30-18

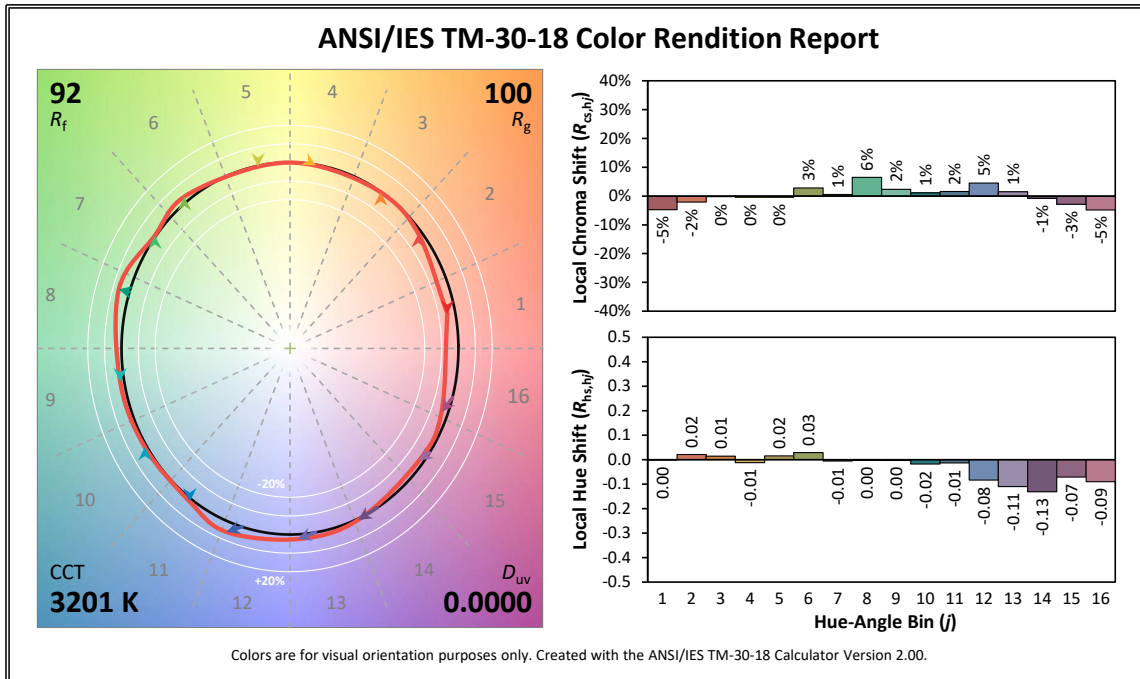

COLOR METRIC INFORMATION

DESIRE D60XTI VIVID 5600 K TM-30-18

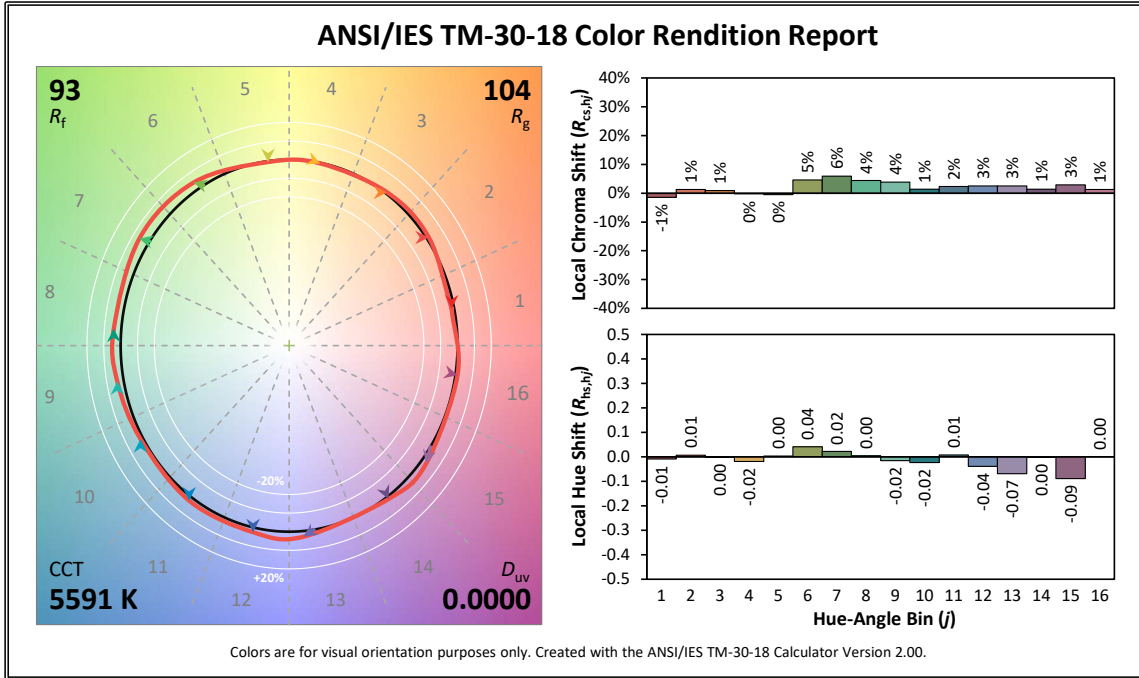

DESIRE D60XTI STUDIO HD 3200 K TM-30-18

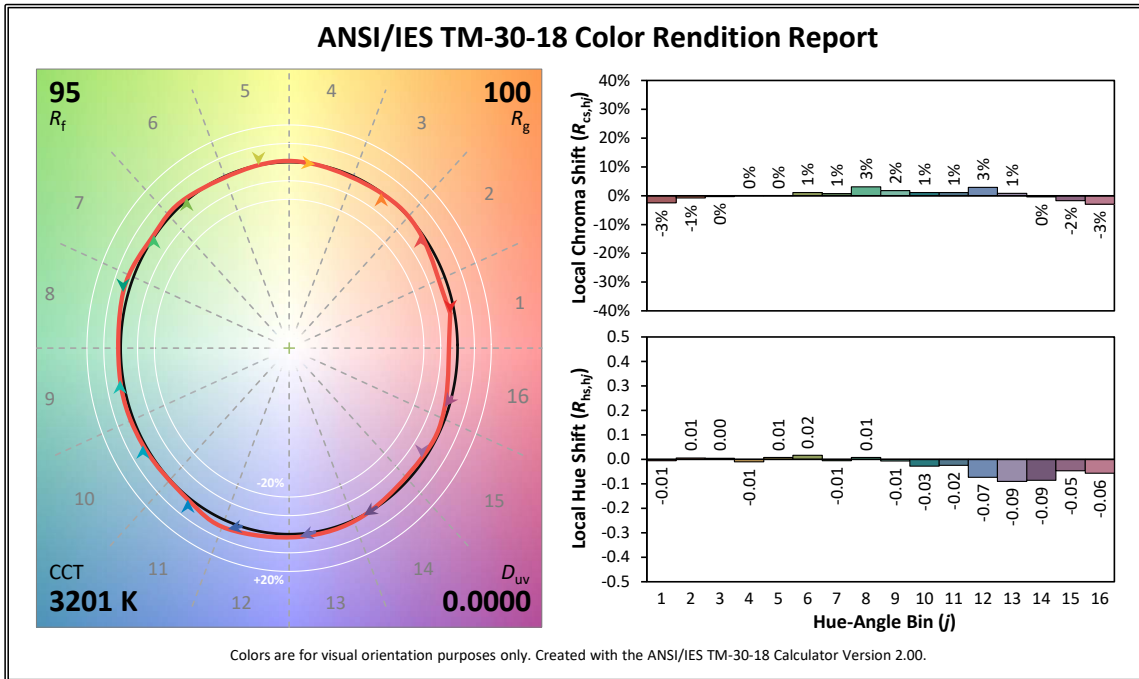

COLOR METRIC INFORMATION

DESIRE D60XTI STUDIO HD 4500 K TM-30-18

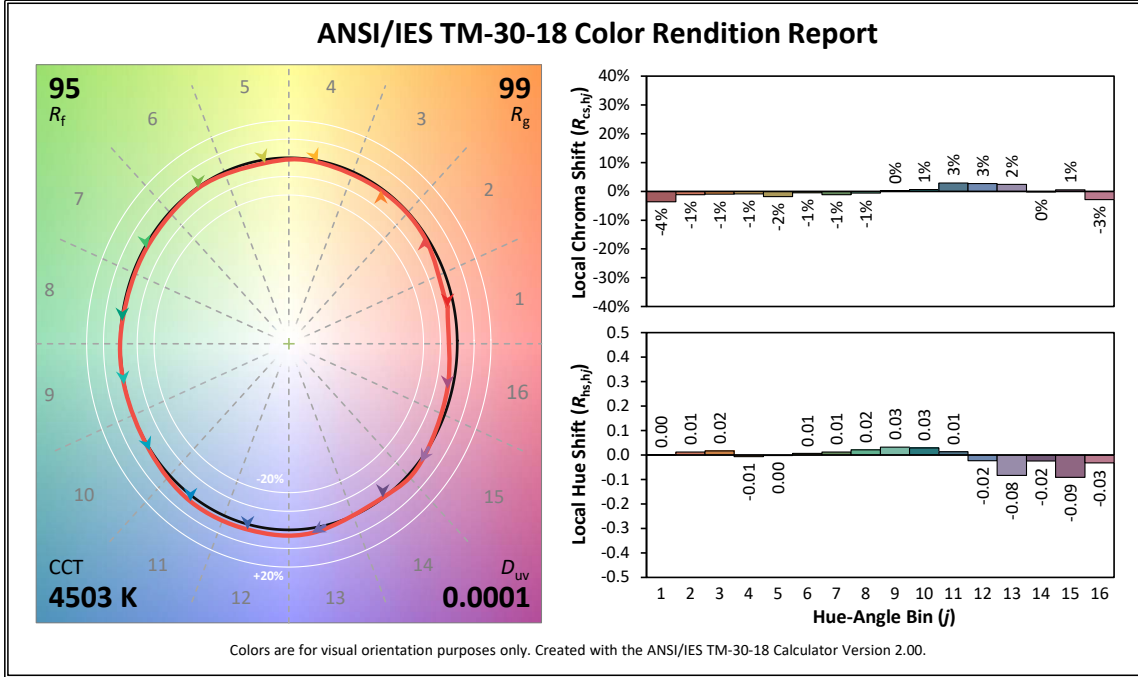

DESIRE D60XTI STUDIO HD 5600 K TM-30-18

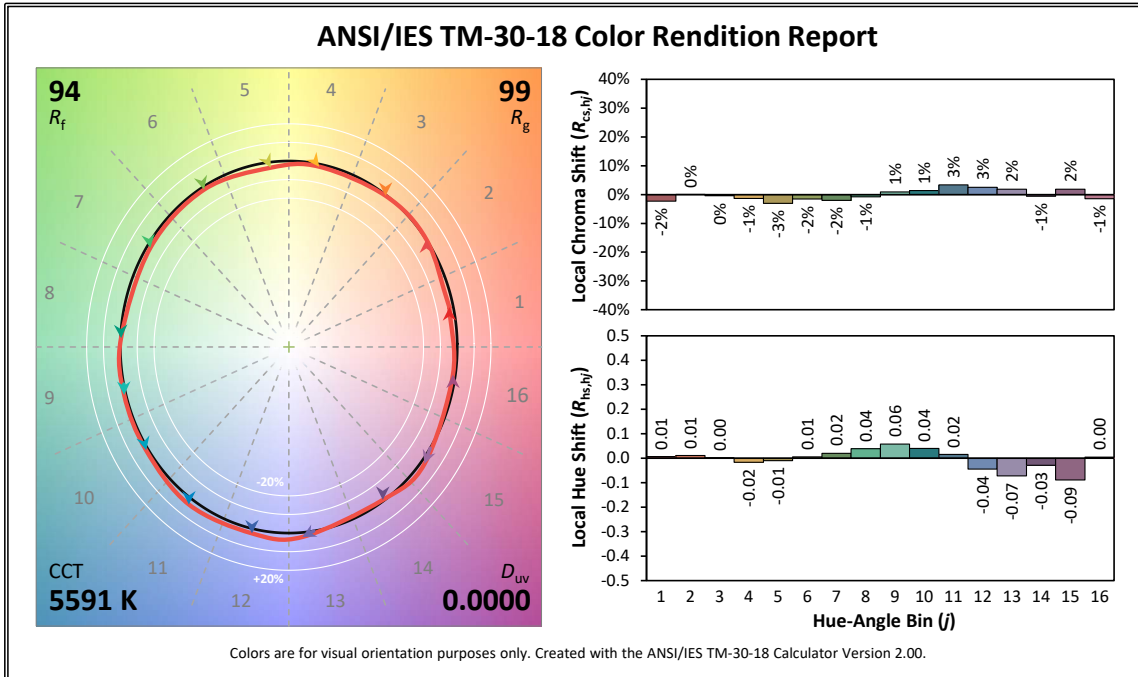

## ADDITIONAL ORDERING INFORMATION

## Secondary Lens Options

The following lenses are cut for D60X luminaires and create round, linear or oblong field patterns as described below. These lenses are not for use in Selador Classic (Vivid, Lustr, ) fixtures.

MODEL	DESCRIPTION:	PART NUMBER
<b>Round Field</b>	<b>Any one of the following round lenses may be installed permanently in the luminaires at the factory as a special order. UV-stable for outdoor use.</b>	
D60XTI-RVN	Very narrow lens (round field)	7410K1073
D60XTI-RN	Narrow lens (round field)	7410K1074
D60XTI-RM	Medium lens (round field)	7410K1075
D60XTI-RW	Wide lens (round field)	7410K1076
D60XTI-REW	Extra Wide lens (round field)	7410K1077
<b>Oblong Field</b>	<b>UV-stable for outdoor use</b>	
D60XTI-ON	Narrow lens (oblong field)	7410K1078
D60XTI-OM	Medium lens (oblong field)	7410K1079
D60XTI-OW	Wide lens (oblong field)	7410K1080

[http://www.etconnect.com/docs/docs\\_downloads/miscdocs/Desire vs PAR EA revB.pdf](http://www.etconnect.com/docs/docs_downloads/miscdocs/Desire_vs_PAR_EA_revB.pdf)

## ADDITIONAL ORDERING INFORMATION

## Fixtures Accessories

MODEL	DESCRIPTION	PART NUMBER
D40XTIWM	Wall-mount kit (black)	7410K1050
D40XTIWM-1	Wall-mount kit (white)	7410K1050-1
D40XTISPM	Single pole mount kit (black)	7410K1051
D40XTISPM-1	Single pole mount kit (white)	7410K1051-1
D40XTIDPM	Double pole mount kit (black)	7410K1052
D40XTIDPM-1	Double pole mount kit (white)	7410K1052-1
D60XTIL	Egg crate (black)	7410K1071
D60XTIL-1	Egg crate (white)	7410K1071-1
D60XTIHH	Half-shield (black)	7410K1072
D60XTIHH-1	Half-shield (white)	7410K1072-1
400CC	C-clamp (does not ship with luminaire)	7060A2009 (not CE)
400SC	Safety cable (32 in)	7060A1022

## CRI AND CQS RATINGS INFORMATION

### CRI AND CQS RATINGS

Desire luminaires were evaluated for CRI and CQS performance using measured output spectrum and optimized mix solutions for a best spectral match to black body sources at 3200 K and 5600 K.

All D60XTI Studio luminaire versions provide excellent color rendering to the eye, particularly at higher color temperature settings such as 5600 K. In most cases the Duv is 0.000. A Duv rating of 0.000 indicates that the color mix used is exactly on the black body line, with no green or magenta tint.

Notes to videographers:

- All Desire luminaires use LUXEON Rebel ES emitters specified by the strictest binning standards. However, on-camera LED response varies with different cameras and settings. Daylight LEDs can appear slightly greener than other 5600 K sources on camera.
- Luminaires with non-variable single-color daylight arrays such as Studio Daylight may use standard color correction filters (Rosco 3314, Rosco 3316 or similar) to achieve the desired on-camera result.
- Camera tests using your specific setup are recommended to determine the best configuration.



**CONTROL OPTIONS**

User settings on D60XTI luminaires allow multiple operational modes and settings for console operation via DMX protocol. Some of the setting options are:

- Multiple DMX options ranging from a simple RGB profile – which effectively controls all seven LED colors via three channels – to nine-channel direct color and intensity control
- Multiple dimming curve options
- Preset colors and sequences for stand-alone (no console required) operation
- White point selection – white light and color behavior based on a specific color temperature white light (i.e., 3200 K, 5600 K, etc)
- Loss of data behavior options – instant-off, hold last look for two minutes, etc.
- Output modes – three output options that offer the user a choice between maximum output and maximum consistency

See the user manual for a complete explanation of all of the control settings and options for the D60XTI

**Quick Setups**

Use one of five Quick Setups on the fixture display to get started. You can modify the setting as needed.

Setting Title	Profile	Description	Typical Features*
General	Direct	Factory default: For general purpose use including interior architectural applications.	<ul style="list-style-type: none"> <li>• Standard dimming curve</li> <li>• Regulated output for color consistency</li> </ul>
Stage	HSI Plus 7 Enabled	Theatrical lighting: Duplicates the color and dimming behavior of tungsten stage lighting fixtures.	<ul style="list-style-type: none"> <li>• Incandescent dimming curve</li> <li>• Regulated output for color consistency</li> <li>• 3200 K white point setting</li> </ul>
XT Arch	HSI	Exterior architectural lighting: Provides a high degree of color consistency in high ambient temperature environments.	<ul style="list-style-type: none"> <li>• Standard dimming curve</li> <li>• Protected output</li> <li>• 3200 K white point setting</li> </ul>
High Impact	RGB	Event lighting: Enables quickest response, simple RGB control and strobe channel for maximum effect usage.	<ul style="list-style-type: none"> <li>• Quick dimming curve</li> <li>• Boost mode for maximum intensity</li> <li>• 5600 K white point setting</li> </ul>
Studio	Studio	Video/film lighting: Enables three parameter control of white light (intensity, white point and tint) via DMX from console.	<ul style="list-style-type: none"> <li>• Linear dimming curve</li> <li>• Regulated output mode for color consistency</li> </ul>

\*See user manual for complete list of features for each Quick Setup.

**CONTROL OPTIONS**

**DMX Input Channel Profiles**

DMX Profile	DMX Channels	Channel Assignments	Notes
Direct	9	1 – Red 2 – Orange (white if Lustr+) 3 – Amber 4 – Green 5 – Cyan 6 – Blue 7 – Indigo 8 – Intensity 9 – Strobe	Direct control of each individual color with a separate master intensity channel. Color calibration of LEDs is not active in this mode. The nine-channel profile will produce the highest quality color crossfades.
HSI	5	1 – Hue (coarse) 2 – Hue (fine) 3 – Saturation 4 – Intensity 5 – Strobe	High-resolution hue (two-channels), saturation and intensity control. HSI mode will produce color crossfades around the color space.
HSIC	6	1 – Hue (coarse) 2 – Hue (fine) 3 – Saturation 4 – Intensity 5 – Strobe 6 – Color Point (CCT)	High-resolution hue, saturation and intensity control as above, with the addition of a color point channel to adjust the color temperature of the luminaire in both white light and color. Color crossfade performance is the same as EHSI.
RGB	5 (Ch. 4 not used)	1 – Red 2 – Green 3 – Blue 4 – n/a 5 – Strobe	Effectively addresses all seven colors via three channels of control. RGB profile will produce medium quality color crossfades.
Studio	3	1 – Intensity 2 – Color Point (CCT) 3 – Tint	Controls luminaire as a white light unit.
Additional profile options			
Plus 7		Seven additional color control channels are available in RGB, HSI, HSIC and Studio profile settings. For example: HSI with Plus 7 enabled becomes a 14-channel profile-	
		1 – Hue (coarse) 2 – Hue (fine) 3 – Saturation 4 – Intensity 5 – Strobe 6 – n/a 7 – Plus 7 control on/off 8 – Red 9 – Orange (white if Lustr+) 10 – Amber 11 – Green 12 – Cyan 13 – Blue 14 – Indigo	<p>The desired color and intensity is achieved by using the HSI or RGB channels.</p> <p>Placing channel seven at a value over 51% gives the luminaire a 14-channel profile.</p> <p>Channels 8-14 represent the native colors of the luminaire and allow the operator to adjust individual color channels to fine-tune the color output.</p>
Strobe			Variable strobe control: 0% is no strobe. The fixture output will strobe more rapidly as the strobe channel value approaches 100%.

CONTROL OPTIONS

Studio Daylight and Studio Tungsten (only)

Quick Setups

Setting Title	Profile	Description	Typical Features
Studio	Studio	Simple mode for linear intensity control	<ul style="list-style-type: none"> <li>Linear dimming curve</li> <li>Regulated output for intensity stability</li> </ul>
Single Channel	Direct	For general purpose architectural use	<ul style="list-style-type: none"> <li>Standard dimming curve</li> <li>Regulated output for consistency</li> </ul>
Stage	Direct	Matches conventional luminaire performance	<ul style="list-style-type: none"> <li>Incandescent dimming curve</li> <li>Regulated output</li> </ul>

DMX Input Channel Profiles

DMX Profile	DMX Channels	Channel Assignments	Notes
Studio	3	1 – Intensity 2 – Strobe 3 – N/A (only used in D60)	Controls luminaire as a white light unit.
Direct	3	1 – Intensity 2 – Strobe 3 – N/A (only used in D60)	

LENS INFORMATION

Desire Diffusion Angle Measurements

NOMINAL									
	No Lens	Very Narrow	Narrow	Medium	Wide	Extra Wide	Narrow Oval	Medium Oval	Wide Oval
<b>D60XTI</b>		25°	35°	45°	75°	N/A	20° x 40°	30° x 70°	35° x 80°
<b>LUSTR+</b>	18	22	27	42	69	104	20 x 37	25 x 60	30 x 82
<b>VIVID</b>	18	22	27	42	69	104	20 x 37	25 x 60	30 x 82
<b>STUDIO HD</b>	18	23	28	42	69	104	21 x 29	25 x 61	30 x 82
<b>STUDIO D</b>	22	25	30	43	70	105	24 x 39	28 x 62	32 x 80
<b>STUDIO T</b>	23	25	30	43	70	105	24 x 39	28 x 62	32 x 80

Values in black refer to old lens descriptions.

PHOTOMETRICS

D60XTI Vivid

Mode	Degree	Candela	Field Lumens	Beam Lumens	Lumens Per Watt
Boost - cold	17°	170,540	3,760	1,667	31.9
Regulated	17°	132,451	3,050	1,305	30

Metric conversions: For meters, multiply feet by 0.3048.  
For lux, multiply foot-candles by 10.76.

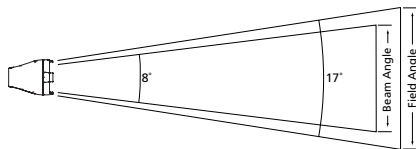

Throw Distance (d)	10.0 ft 3.0 m	15.0 ft 4.6 m	20.0 ft 6.1 m	25.0 ft 7.6 m	319 ft 97 m
Field Diameter	3.0 ft .9 m	4.4 ft 1.4 m	5.9 ft 1.8 m	7.4 ft 2.3 m	-
Illuminance (fc)	1,617	719	404	259	1
Illuminance (lux)	17,405	7,736	4,351	2,785	10.76

To determine center beam illumination in foot-candles at any throw distance, divide candela by the throw distance squared.

For field diameter at any distance, multiply distance by 0.295.  
For beam diameter at any distance, multiply by 0.145.

Cosine Candela Plot

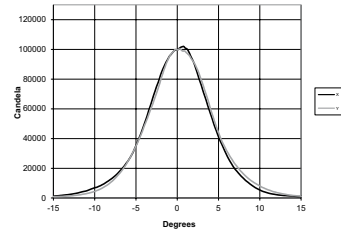

Iso-Illuminance Diagram (Flat Surface Distribution)

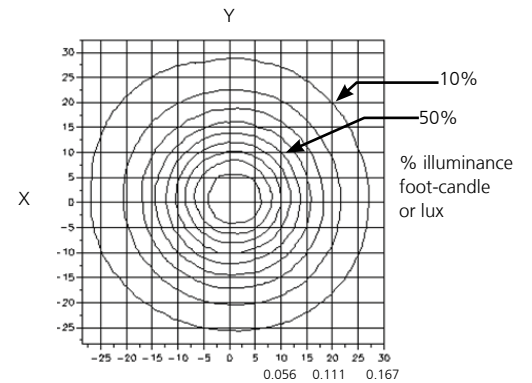

D60XTI Lustr+

Mode	Degree	Candela	Field Lumens	Beam Lumens	Lumens Per Watt
Boost - cold	16°	195,012	4,317	1,931	34.9
Regulated	16°	180,097	3,850	1,748	34.3

Metric conversions: For meters, multiply feet by 0.3048.  
For lux, multiply foot-candles by 10.76.

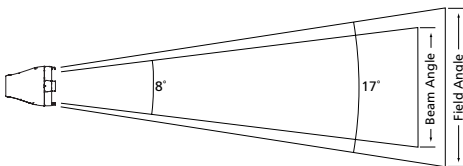

Throw Distance (d)	10 ft 3.0 m	15.0 ft 4.6 m	20.0 ft 6.1 m	25.0 ft 7.6 m	348 ft 106 m
Field Diameter	2.9 ft .9 m	4.3 ft 1.3 m	5.8 ft 1.8 m	7.2 ft 2.2 m	-
Illuminance (fc)	1,828	812	457	292	1
Illuminance (lux)	19,676	8,745	4,919	3,148	10.76

To determine center beam illumination in foot-candles at any throw distance, divide candela by the throw distance squared.

For field diameter at any distance, multiply distance by 0.288.  
For beam diameter at any distance, multiply by 0.112.

Cosine Candela Plot

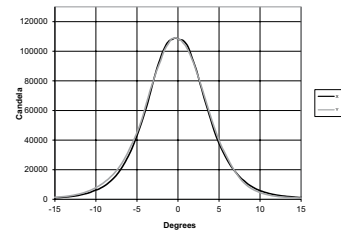

Iso-Illuminance Diagram (Flat Surface Distribution)

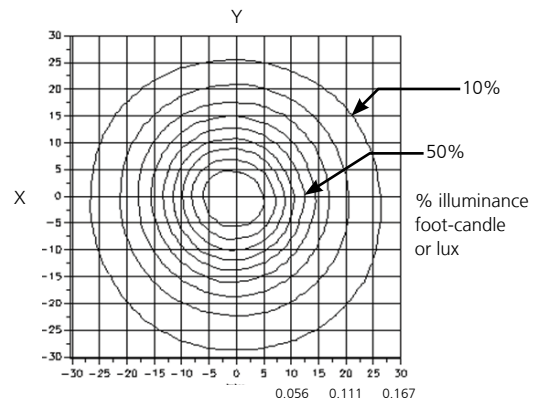

PHOTOMETRICS

D60XTI Studio HD

Mode	Degree	Candela	Field Lumens	Beam Lumens	Lumens Per Watt
Boost - cold	16°	198,209	4,532	1,916	33.4
Regulated	16°	185,414	4,224	1,780	33.7

Metric conversions: For meters, multiply feet by 0.3048.  
For lux, multiply foot-candles by 10.76.

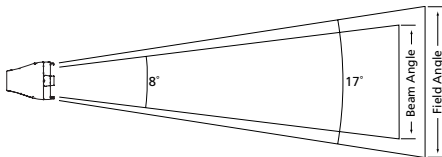

Throw Distance (d)	10.0 ft 3.0 m	15.0 ft 4.6 m	20.0 ft 6.1 m	25.0 ft 7.6 m	471.4 ft 143.7 m
Field Diameter	2.8 ft 0.9 m	4.2 ft 1.3 m	5.6 ft 1.7 m	7.0 ft 2.1 m	-
Illuminance (fc)	2,222	988	556	356	1
Illuminance (lux)	23,917	10,630	5,979	3,827	10.76

To determine center beam illumination in foot-candles at any throw distance, divide candela by the throw distance squared.

For field diameter at any distance, multiply distance by 0.281.  
For beam diameter at any distance, multiply by 0.142.

Cosine Candela Plot

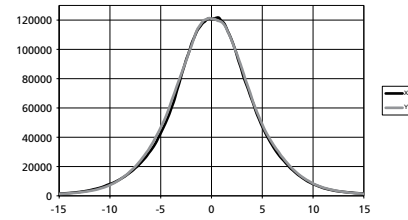

Iso-Illuminance Diagram (Flat Surface Distribution)

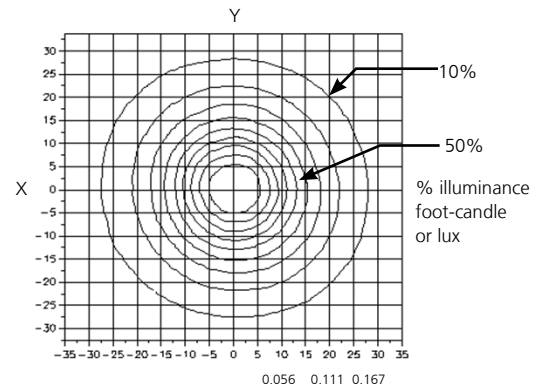

D60XTI Studio Daylight

Mode	Degree	Candela	Field Lumens	Beam Lumens	Lumens Per Watt
Boost - cold	22°	209,556	8,216	4,068	55.3
Regulated	22°	193,045	7,610	3,860	54.8

Metric conversions: For meters, multiply feet by 0.3048.  
For lux, multiply foot-candles by 10.76.

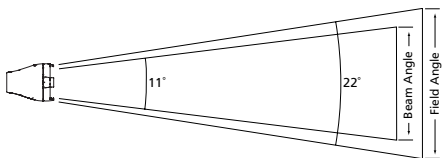

Throw Distance (d)	10 ft 3.0 m	15 ft 4.6 m	20 ft 6.1 m	25 ft 7.6 m	435.3 ft 132.7 m
Field Diameter	3.9 ft 1.2 m	5.8 ft 1.8 m	7.7 ft 2.4 m	9.7 ft 2.9 m	-
Illuminance (fc)	1,895	842	474	303	1
Illuminance (lux)	20,398	9,066	5,099	3,264	10.76

To determine center beam illumination in foot-candles at any throw distance, divide candela by the throw distance squared.

For field diameter at any distance, multiply distance by 0.387.  
For beam diameter at any distance, multiply by 0.194.

Cosine Candela Plot

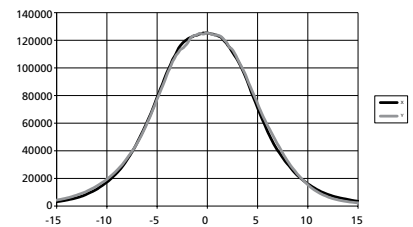

Iso-Illuminance Diagram (Flat Surface Distribution)

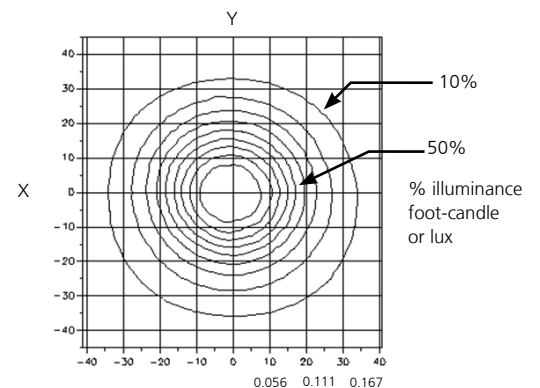

PHOTOMETRICS

D60XTI Studio Tungsten

Mode	Degree	Candela	Field Lumens	Beam Lumens	Lumens Per Watt
Boost - cold	23°	171,089	6,482	3,001	43.2
Regulated	23°	162,409	6,172	2,918	39.6

Metric conversions: For meters, multiply feet by 0.3048.  
For lux, multiply foot-candles by 10.76.

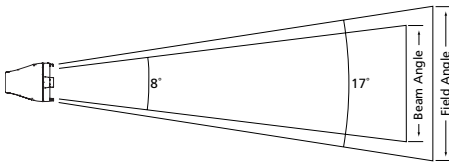

Throw Distance (d)	10 ft 3.0 m	15 ft 4.6 m	20 ft 6.1 m	25 ft 7.6 m	373.6 ft 113.9 m
Field Diameter	4.1 ft 1.3 m	6.2 ft 1.9 m	8.3 ft 2.5 m	10.4 ft 3.2 m	-
Illuminance (fc)	1,395	620	349	223	1
Illuminance (lux)	15,020	6,676	3,755	2,403	10.76

For field diameter at any distance, multiply distance by 0.414.  
For beam diameter at any distance, multiply by 0.189.

**THROW DISTANCE MULTIPLIER (TDM)**

To determine the distance from the center of the beam (Origin) to a certain illuminance level at a particular distance, multiply the desired throw distance by the TDM desired on the Iso-Illuminance diagram.

Throw Distance (TD) x Throw Distance Multiplier (TDM) = Distance from the Origin (DfO) (distance from the center of the beam)

Example: 25 feet (TD) x 0.047 (TDM) = 1.175 feet from center of beam (DfO)

For illumination with any lamp, multiply the candlepower of a beam spread by the multiplying factor (mf) shown for that lamp.

To determine illumination in footcandles or lux at any throw distance, divide candlepower by distance squared.

**Cosine Candela Plot**

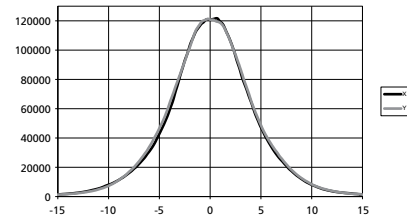

**Iso-Illuminance Diagram (Flat Surface Distribution)**

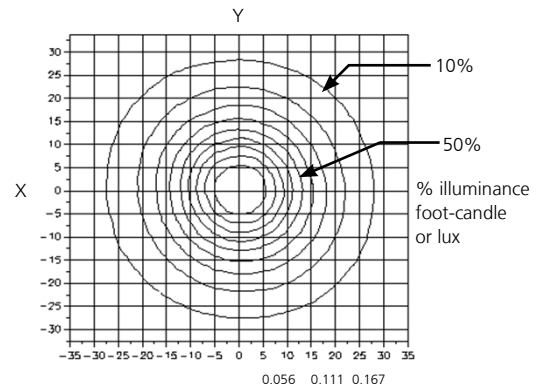

PHYSICAL

Selador D60XTI Weights and Dimensions

Total weight depends on how the individual luminaire is configured.

WEIGHT*		SHIPPING WEIGHT	
lb	kg	lb	kg
23	10.5	24.7	11.2

\* Does not include mounting hardware

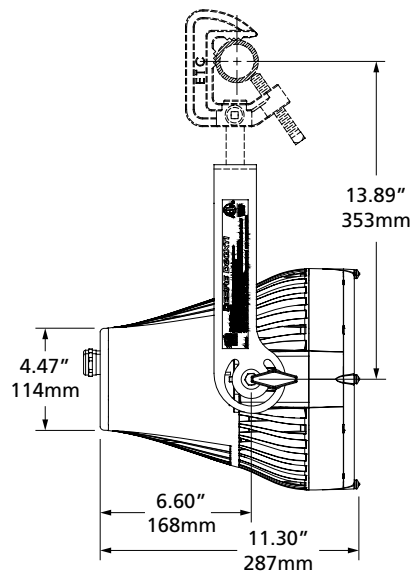
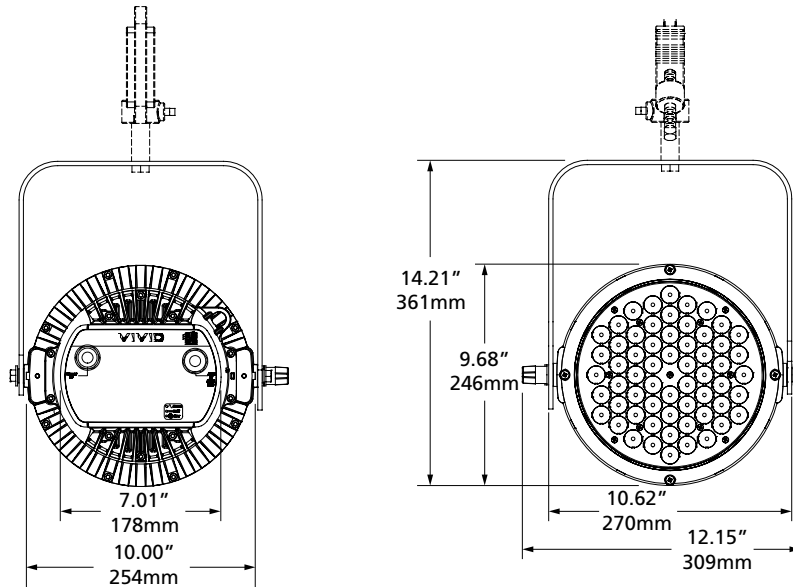

Corporate Headquarters • Middleton, WI USA  
 Global Offices • London, UK • Rome, IT • Holzkirchen, DE • Paris, FR • Hong Kong  
 Dubai, UAE • Singapore • New York, NY • Orlando, FL • Los Angeles, CA • Austin, TX  
 ©2023 ETC. All Rights Reserved. All product information and specifications subject to change. Rev L 2024-05  
 \*Trademark and patent info: [etcconnect.com/IP](http://etcconnect.com/IP) • Third-party license agreement info: [etcconnect.com/licenses](http://etcconnect.com/licenses)

