

.....

QuickLock
Portable Stage System
by Intellistage



QuickLock™
12662 Corral Place Santa Fe Springs CA 90670
Ph: 562.906.6185 Fax: 562.906.6186
Email: usa@quicklockstaging.com www.quicklockstaging.com



QuickLock

Portable Stage System

by Intellistage

Contents

Introduction	2
Limited 2 Year Warranty	2
Imperial Skus	3
Metric Skus.....	4
Meet the Components	5
Specifications and Features	6
Platform and Leg Assembly	7
Adjusting Leg Height	8
Connecting Multiple Platforms	9,10
Attaching Guardrails	11,12
Connecting Multiple Guardrails.....	13
Attaching Chair Stops	14,15
Attaching Stairs	16,17

Introduction

Thank you for being a QuickLock Customer and welcome to the family.

We do one thing and do it well – build products that make your life easier. Crafting innovative, quality products is our calling and we take it seriously. Strong, lightweight and versatile, your QuickLock system is crafted out of the finest materials available and put through our grueling quality check before it ships out the door.

We thank you for your purchase and know that your QuickLock system will definitely steal the show! However, if you should require any assistance or service, you'll find that we take as much pride in supporting our products as we do in designing and building them.

About QuickLock

Perfect for schools, houses of worship, hotels and event organizers, QuickLock portable stage systems are the ultimate in portability and convenience. Consisting of modular, lightweight platforms and legs that can be combined to create customized stages in various heights and configurations. Easily assembled by a single person, each platform can bear weight up to 153 lbs./sq. ft (750 kgs/sq. meter) When it's time to break down, you'll find that disassembly and storage are equally convenient. Learn more about QuickLock at www.quicklockstaging.com

Limited 2 Year Warranty

QuickLock warrants to the original owner of each new QuickLock product, for a period of 2 years from the date of purchase, (provided that is purchased at an Authorized QuickLock Dealer) that is free of defects in materials and workmanship and that each product meets or exceeds all factory published specifications. This warranty is void if the product has been tampered with or misused beyond reasonable wear, and shall not apply if the product has been physically damaged. Improper handling, set-up or use of this unit could cause it to fail which could lead to serious injury or death. Please be sure to read, understand and follow all operating instructions and weight load information in this manual before using this product. Do not allow children or untrained persons to use this product. There are no obligations of liability on the part of QuickLock for any personal injuries, death, consequential damage or any other indirect damages with respect to, loss of property, revenues, profit or costs of removals, installations or re-installations arising out of, or in connection with, the use or performance of a QuickLock product.

Imperial SKUS

Panels	
QLP31*	Industrial finish 3ft x 3ft platforms with integrated platform to platform locking system - single pack
QLP3C	Gray carpet finish 3ft x 3ft platforms with integrated platform to platform locking system - single pack
QLP41*	Industrial finish 4ft x 4ft platforms with integrated platform to platform locking system - single pack
QLP4C	Gray carpet finish 4ft x 4ft platforms with integrated platform to platform locking system - single pack
QLP4AL	Aluminium finish, water proof 4ft x 4ft platforms with integrated platform to platform locking system - single pack

Legs

QLTL1	Telescopic leg adjustable from 16" to 24" - single pack
QLTL2	Telescopic leg adjustable from 24" to 32" - single pack
QL4TL1*	Telescopic leg adjustable from 16" to 24" - four pack
QL4TL2*	Telescopic leg adjustable from 24" to 32" - four pack
QLFL8	Fixed leg for 8" high stage - single pack
QLFL16	Fixed leg for 16" high stage - single pack
QLFL24	Fixed leg for 24" high stage - single pack
QLFL32	Fixed leg for 32" high stage - single pack
QL4FL16	Fixed leg for 16" high stage - four pack
QL4FL24	Fixed leg for 24" high stage - four pack
QL4FL32	Fixed leg for 32" high stage - four pack
QLMFL8*	Fixed leg for 8" high stage with casters - four pack no brakes
QLMFL8B*	Fixed leg for 8" high stage with casters - four pack with brakes
QLMFL16*	Fixed leg for 16" high stage with casters - four pack no brakes
QLMFL16B*	Fixed leg for 16" high stage with casters - four pack with brakes

Stairs

QLSTAIR1L	Fixed stair system for 16" high stages - consists of 1 step at 8", with wheels. No handrails
QLSTAIR1*	Fixed stair system for 16" high stages - consists of 1 step at 8" high, handrails and wheels
QLSTAIR2*	Fixed stair system for 24" high stages - consists of 2 steps at 8", 16" high, handrails and wheels
QLSTAIR3*	Fixed Stair System for 32" high stages - consists of 3 steps at 8", 16", 24" high, handrails and wheels

Quicklock Dual Height Stair Kits

QLSTAIR1624	Dual height stair kit for 16" or 24" adjustable stage
QLSTAIR2432	Dual height stair kit for 24" or 32" adjustable stage
AQLE*	4" QuickLock universal Stairs Adapter for Stairs installation on QuickLock stage

Guardrails

QLGRD3*	Guardrails for 3x3 platform with clamp and mounting hardware - dual pack
QLGRD4*	Guardrails for 4x4 platform with clamp and mounting hardware - dual pack

Transportation

TCART*	Platform cart - Transports up to 7 platforms - Fits through standard doors
--------	--

Skirts

QLSCLIP8*	8 pack of clips to attach skirts to platforms
QLS8x8*	8" wide 8" skirt - with clips
QLS8X16*	8" wide 16" skirt - with clips
QLS8X24*	8" wide 24" skirt - with clips
QLS8X32*	8" wide 32" skirt - with clips

Chair Stops

QLCS8X4	8" high, 4" long chair stop with mounting hardware -single pack
QLCS2X4	2" high, 4" long chair stop with mounting hardware -single pack

Accessories

QLSLI*	Self-leveling platform insert - single
QL10SLI*	Self-leveling platform insert - ten pack
QLDAI*	Double assembly inserts - single
QL10DAI*	Double assembly inserts - ten pack
QLAI	Single assembly inserts - single
QL10AI	Single assembly inserts - ten pack
QLGRCLAMP	Set of guardrail mounting hardware - single pack
QLGRCBD	Mounting hardware for guardrails- dual pack

* Only Skus shown with an * next to them are available in the US

Metric SKUS

Panels

QLEP11	Industrial finish 1m x 1m platform with integrated platform to platform locking system - single pack
QLEP1C	Gray carpet finish 1m x 1m platform with integrated platform to platform locking system - single pack
QLEP1AL	Aluminium finish, water proof 1m x 1m platforms with integrated platform to platform locking system - single pack
QLEP1X2I	Industrial finish 1m x 2m platform with integrated platform to platform locking system - single pack
QLEP1X2C	Gray carpet finish 1m x 2m platform with integrated platform to platform locking system - single pack
QLEP1X2AL	Aluminium finish, water proof 1m x 2m platforms with integrated platform to platform locking system - single pack

Legs

QLETL1	Telescopic leg adjustable from 40 to 60CM - single pack
QLETL2	Telescopic leg adjustable from 60 to 80CM - single pack
QLE4TL1	Telescopic leg adjustable from 40 to 60CM - four pack
QLE4TL2	Telescopic leg adjustable from 60 to 80CM - four pack
QLFL20	Fixed Leg for 20cm high stage - single pack
QLFL40	Fixed Leg for 40cm high stage - single pack
QLFL60	Fixed Leg for 60cm high stage - single pack
QLFL80	Fixed Leg for 80cm high stage - single pack
QL4FL40	Fixed Leg for 40cm high stage - four pack
QL4FL60	Fixed Leg for 60cm high stage - four pack
QL4FL80	Fixed Leg for 80cm high stage - four pack
QLMFL20	Fixed Leg for 20cm high stage with casters - four pack
QLMFL20B	Fixed Leg for 20cm high stage with casters - four pack with brakes
QLMFL40	Fixed Leg for 40cm high stage with casters - four pack - no brakes
QLMFL40B	Fixed Leg for 40cm high stage with casters - four pack with brakes

Stairs

QLSTAIR1L	Fixed stair system for 40 cm high stages - consists of 1 step at 20cm with wheels. No handrails
QLSTAIR1E	Fixed stair system for 40cm high stages - consists of 1 step at 20cm high, handrails and wheels
QLSTAIR2	Fixed stair system for 60cm high stages - consists of 2 steps at 20cm, 40cm high, handrails and wheels
QLSTAIR3	Fixed Stair System for 80cm high stages - consists of 3 steps at 20cm, 40cm, 60cm high, handrails and wheels

Quicklock Dual Height Stair Kits

QLSTAIR4060	Dual height stair kit for 40cm or 60cm adjustable stage
QLSTAIR6080	Dual height stair kit for 60cm or 80cm adjustable stage
AQLE	1M QuickLock universal Stairs Adapter for Stairs installation on QuickLock stage

Guardrails

QLGRD1	Guardrails for 1m x 1m platform with mounting hardware - dual pack
QLGRS1	Guardrails for 1m x 1m platform with mounting hardware - single pack

Transportation

TCART	Platform Cart - Transports up to 7 Platforms - Fits through Standard Doors
-------	--

Skirts

QLSClip8	8 pack of clips to attach skirts to platforms
QLS2X20	2m wide 20cm skirt - with clips
QLS2X40	2m wide 40cm skirt - with clips
QLS2X60	2m wide 60cm skirt - with clips
QLS2X80	2m wide 80cm skirt - with clips

Chair Stops

QLCS20X1	20cm high, 1m long chair stop with mounting hardware -single pack
QLCS5X1	5cm high, 1m long chair stop with mounting hardware -single pack

Accessories

QLSLI	Self-leveling platform insert - single
QL10SLI	Self-leveling platform insert - ten pack
QL10DAI	Double assembly inserts - ten pack
QLDAI	Double assembly inserts - single
QLAI	Single assembly inserts - single
QL10AI	Single assembly inserts - ten pack
QLGRCLAMP	Set of guardrail mounting hardware - single pack
QLGRCBD	Mounting hardware for QuickLock Guardrails- dual pack

Meet the Components:

Putting together your QuickLock system was designed to be simple enough for anyone to do. Consequently, the number of components you will encounter in the assembly process is limited. Nonetheless, let's take a moment for a little meet and greet...

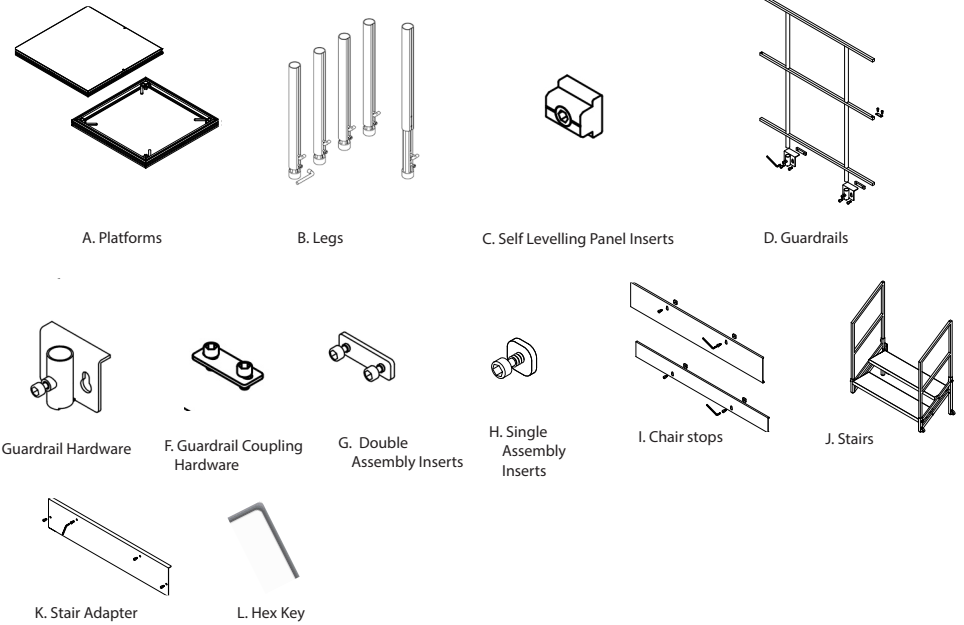

A. Platforms

Durable, modular stage surface - supports up to 153 lbs./sq. ft. (750kg/sq. meter).

B. Legs

Support platforms - available in fixed and height adjustable versions.

C. Self Levelling Inserts

Used to level panels when they are being connected.

D. Guardrails

Guardrails are an optional add on to any stage. They add an additional measure of safety for performers.

E. Guardrail Mounting Hardware

Attaches to stage platform with double assembly insert G and guardrails are placed into the hardware.

F. Guardrail Coupling Hardware

Used to connect multiple guardrails together.

I. Chair Stops

Chair stops are an optional add on to any stage. They prevent chairs from sliding off the stage.

J. Stairs

Stairs are recommended to use with any stage that is being set-up higher than 8".

K. Stair Adapter

Used to attach stairs to the stage platform.

L. Hex Key

Used to secure and fasten different components of the stage system.

Specifications and Features:

Imperial

- Light weight panels, super strong.
- Can be set-up on uneven ground.
- Set-up by one person with no extra tools.
- Available in 4' x 4' or 3' x 3' panel sizes.
- Feature height adjustable telescoping legs that adjust stage height from 16" up to 24" or 24" to 32" high or your choice of fixed legs 8", 16" 24" or 32" high
- Available in industrial, carpet or waterproof aluminium finish.
- Stairs, guardrails, skirts and transportation trolleys are available.

Weight rated at: (153 lbs /sq ft) 750 kg/sq. meter.

Metric

- Light weight panels, super strong.
- Can be set-up on uneven ground.
- Set-up by one person with no extra tools.
- Available in 1m x 1m and 1m x 2m panel sizes.
- Feature height adjustable telescoping legs that adjust stage height from 40cm to 60cm or 60cm to 80cm high or your choice of fixed legs 20cm, 40cm, 60cm or 80cm high.
- Available in industrial, carpet or waterproof aluminium finish.
- Stairs, guardrails, skirts and transportation trolleys are available.

Weight rated at: (153 lbs /sq ft) 750 kg/sq. meter.

Platform and Leg Assembly

1. Unpack legs and platforms.

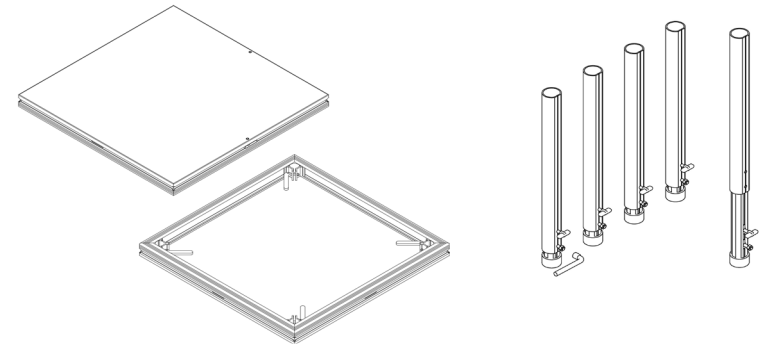

2. Place platforms upside down and place all 4 legs into sockets as shown.

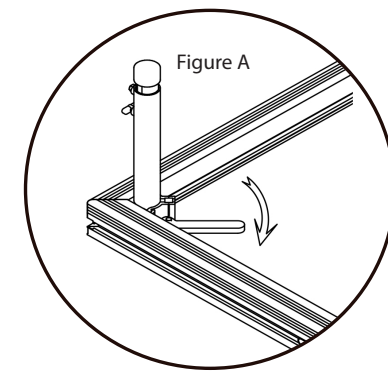
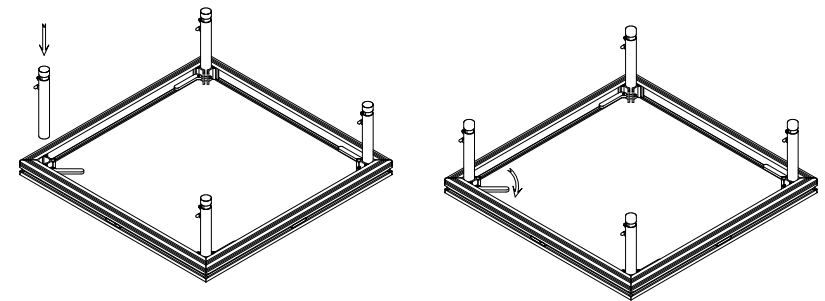

3. Make sure to fully insert the legs into sockets. Then lock legs into place as shown in Figure A. by moving locking lever until it locks securely into place.



Important Safety Instructions:

- 1.) Read and follow all instructions
- 2.) Do not exceed the maximum weight capacity
- 3.) Before use, completely secure all fasteners as per instruction manual

Adjusting leg Height

1. Adjust telescoping legs to the height you would like by extending them as shown in Figure B and secure them by tightening knob C by hand.

Figure B

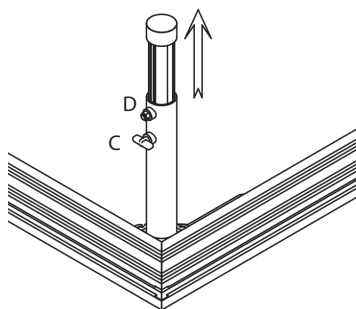

2. Repeat same procedure for all legs on all platforms that will be connected. If setting up stage on uneven terrain, please adjust legs accordingly to take account for the uneven ground. Place all assembled platforms on the ground upright and use a level to make sure that all of them are levelled properly.

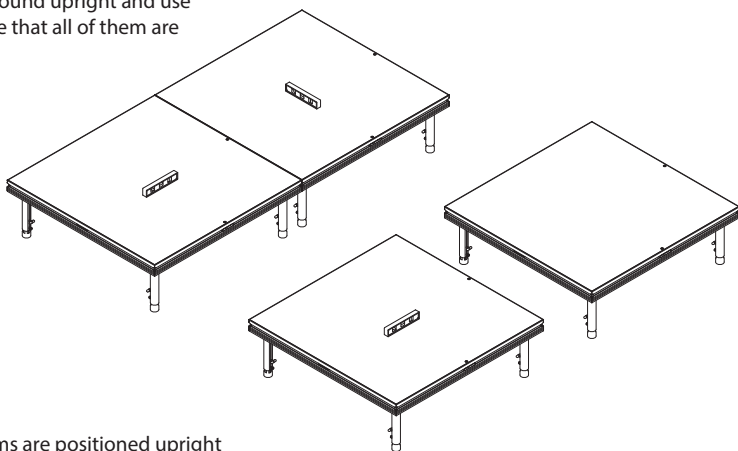

3. Once all platforms are positioned upright and properly levelled. Place the hex key into hex key Lock D and tighten the lock with the hex key until leg is locked into place as shown in Figure C.

Figure C

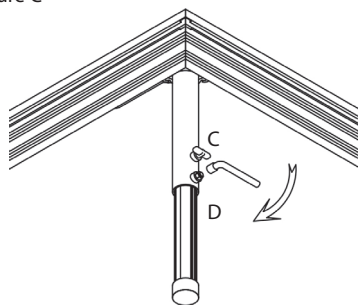

4. Repeat this procedure for all the legs on all platforms and make sure hex key lock D and knob C are both securely tightened.

Connecting Multiple Platforms

Components Needed

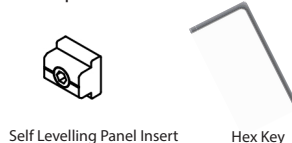

1. To connect platforms set them next to each other.

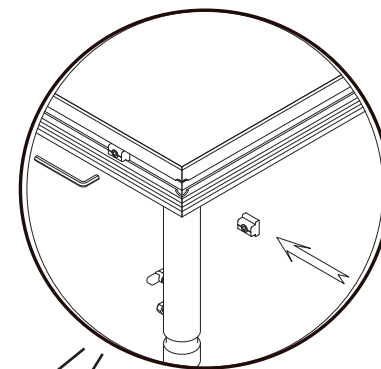

Slide self levelling panel insert into the channel in the frame of the platform and secure with hex key

Figure D

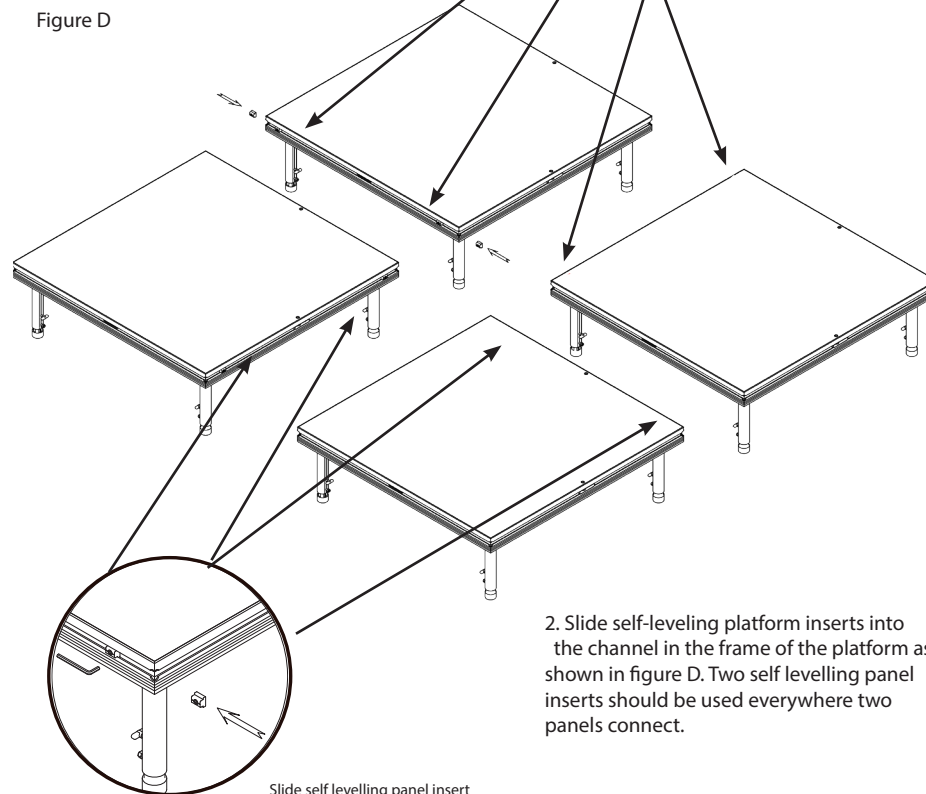

2. Slide self-leveling platform inserts into the channel in the frame of the platform as shown in figure D. Two self levelling panel inserts should be used everywhere two panels connect.

Slide self levelling panel insert into the channel in the frame of the platform and secure with hex key

Connecting Multiple Platforms

3. Place platforms together and connect them by using hex key as shown in Figure E anywhere two platforms meet. Please make sure the locks engage fully.

Figure E

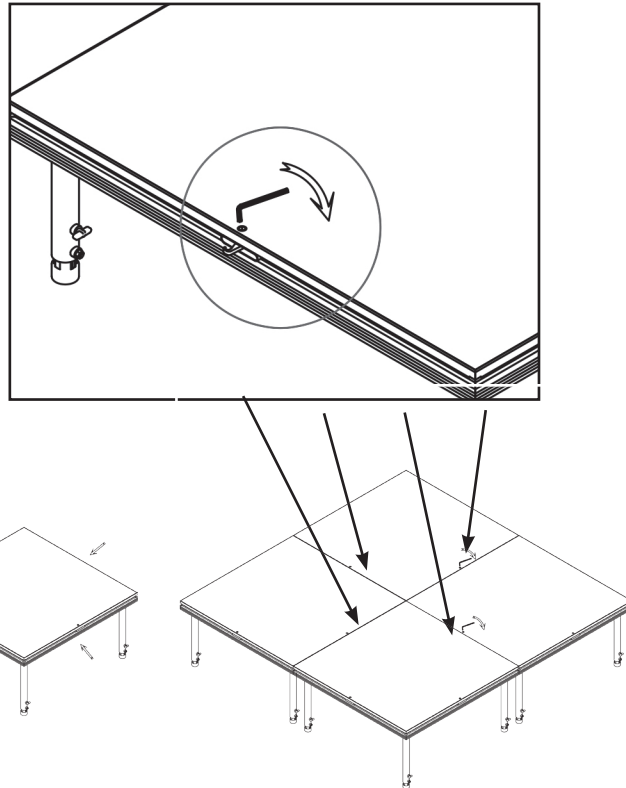

Attaching guardrails

Components Needed

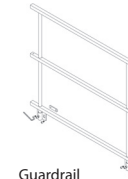
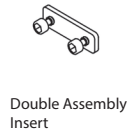

1. Slide double assembly insert into the channel in the frame of the platform as shown in Figure F.

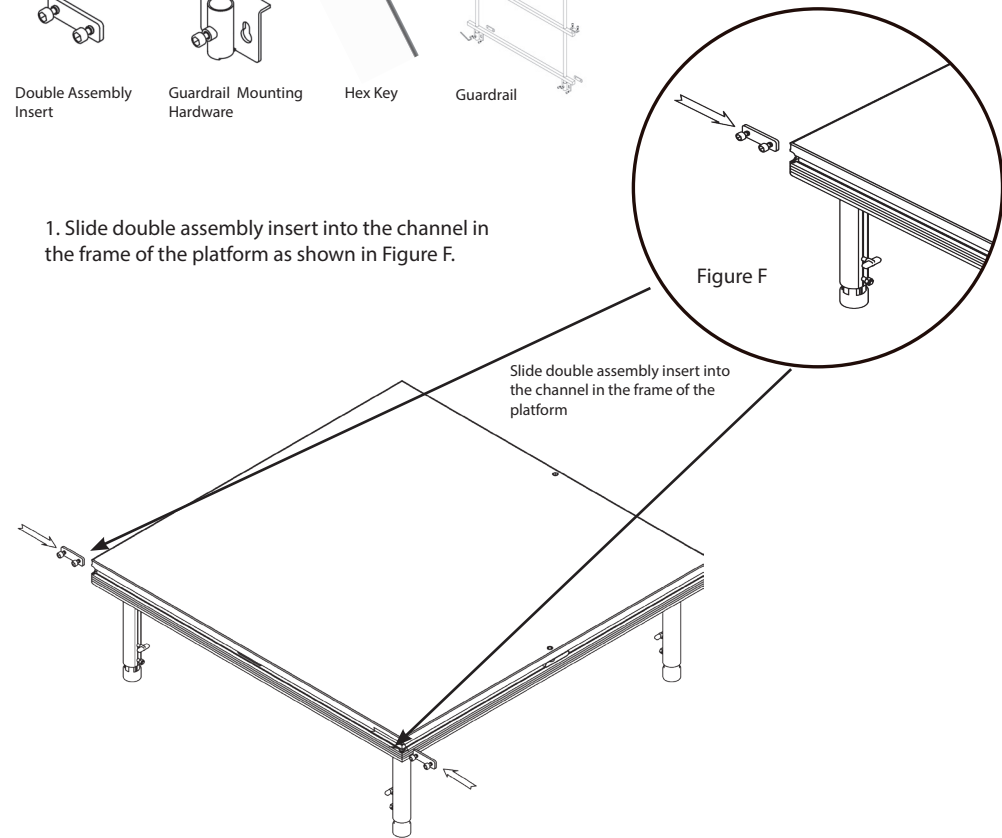

2. Attach guardrail mounting hardware onto double assembly inserts as shown in Figure G.

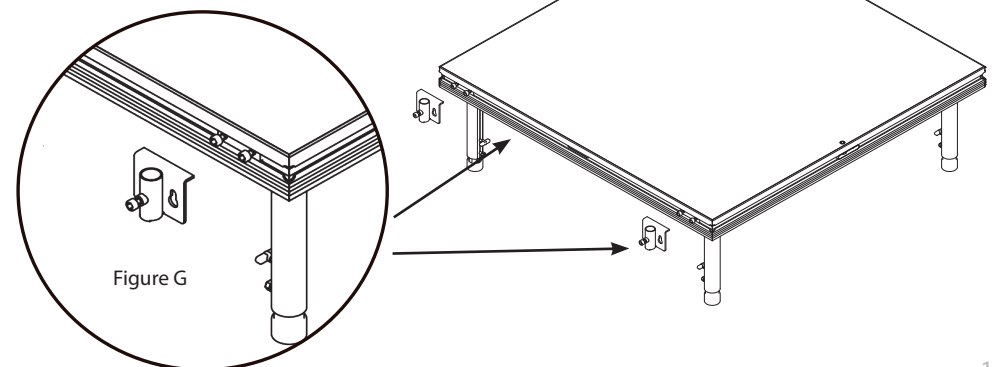

Attaching guardrails

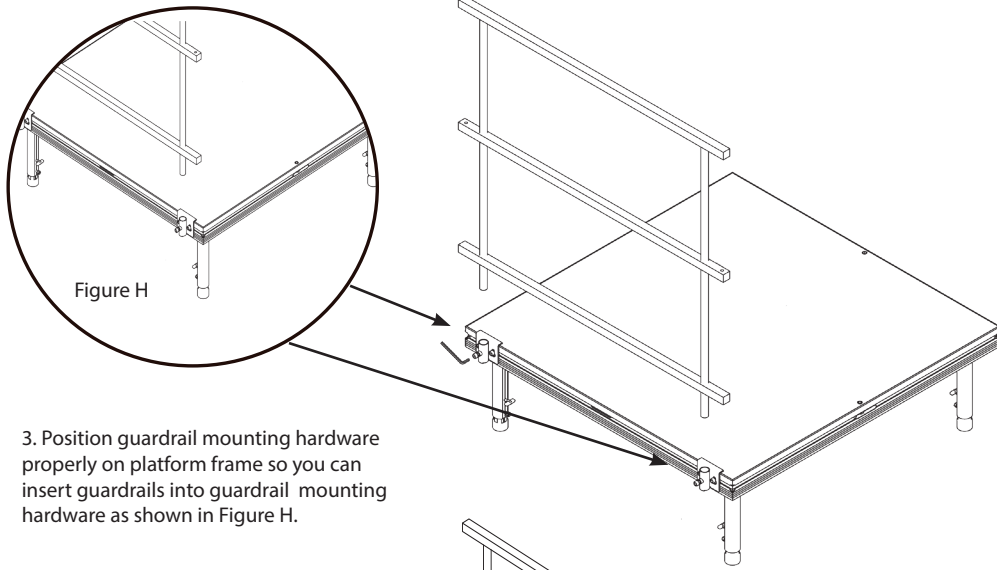

3. Position guardrail mounting hardware properly on platform frame so you can insert guardrails into guardrail mounting hardware as shown in Figure H.

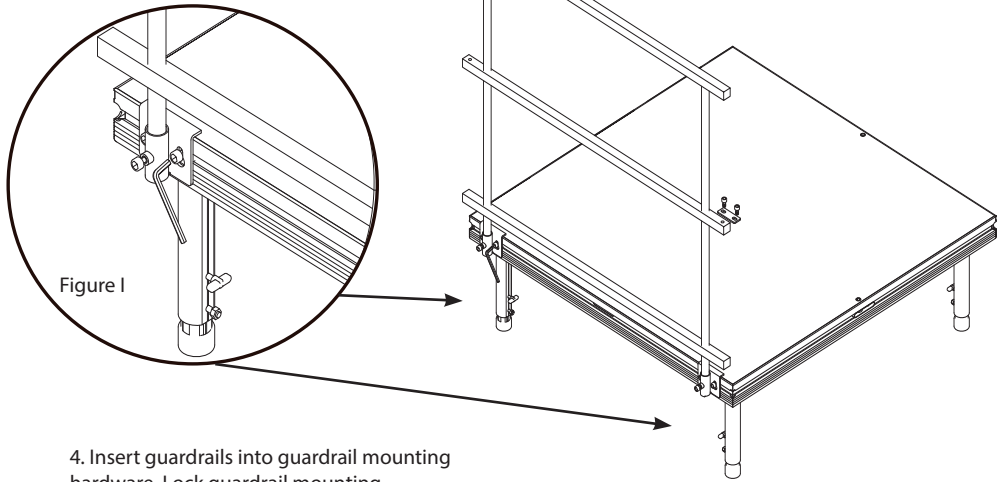

4. Insert guardrails into guardrail mounting hardware. Lock guardrail mounting hardware to platform using hex key as shown in Figure I.

5. Lock guardrails into guardrail mounting hardware using hex key as shown in Figure J. Repeat for all remaining guardrails.

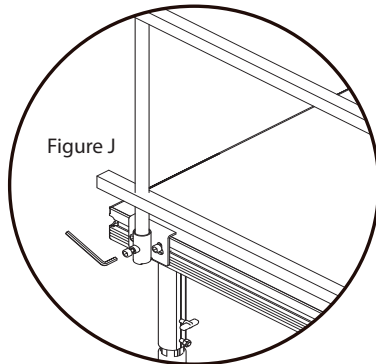

Connecting multiple guardrails

Components Needed

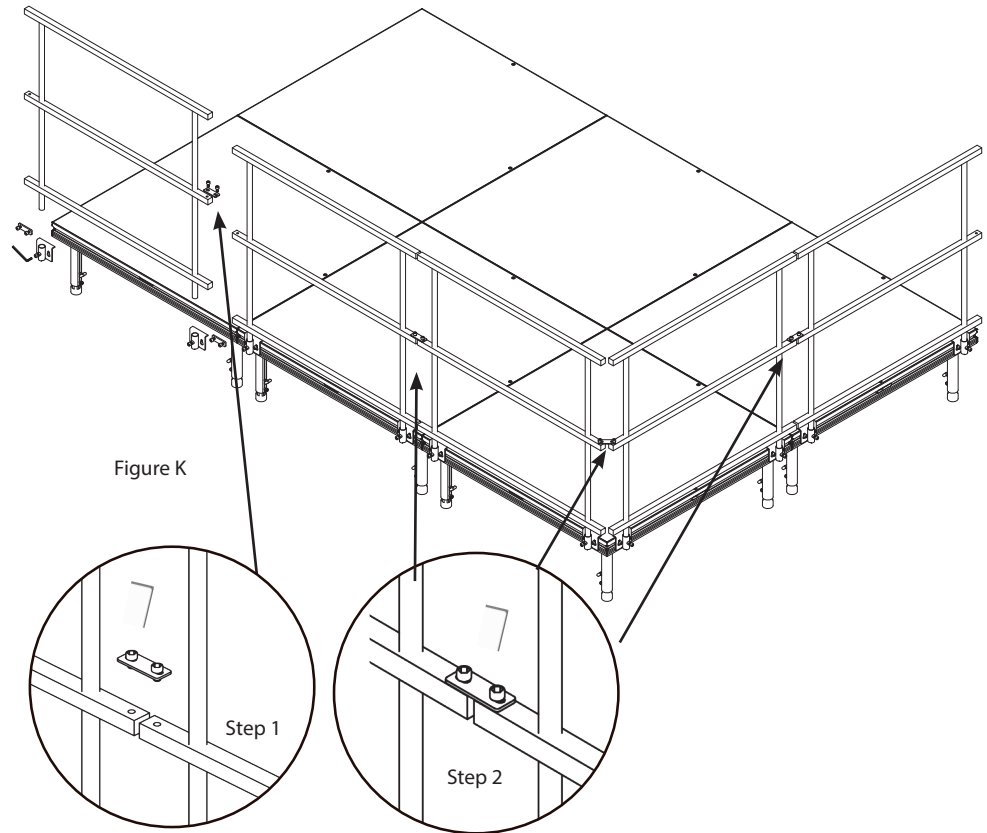
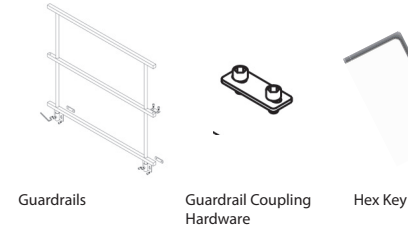

1. Connect multiple guard rails together with coupling hardware as shown in Step 1 and 2 in Figure K and tighten with hex key.

Attaching Chair Stops

Components Needed

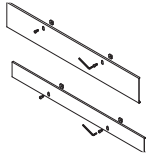

Chair stops



Single Assembly Insert



Hex Key

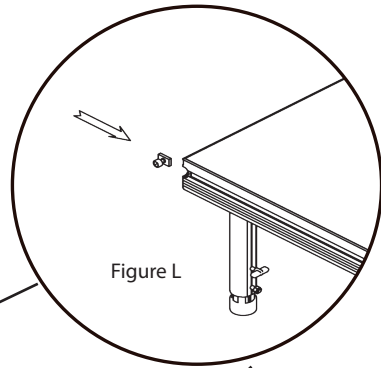

Figure L

Slide single assembly insert into the channel in the frame of the platform

1. Slide single assembly insert into the channel in the frame of the platform as shown in Figure L.

Attaching Chair Stops

Figure M

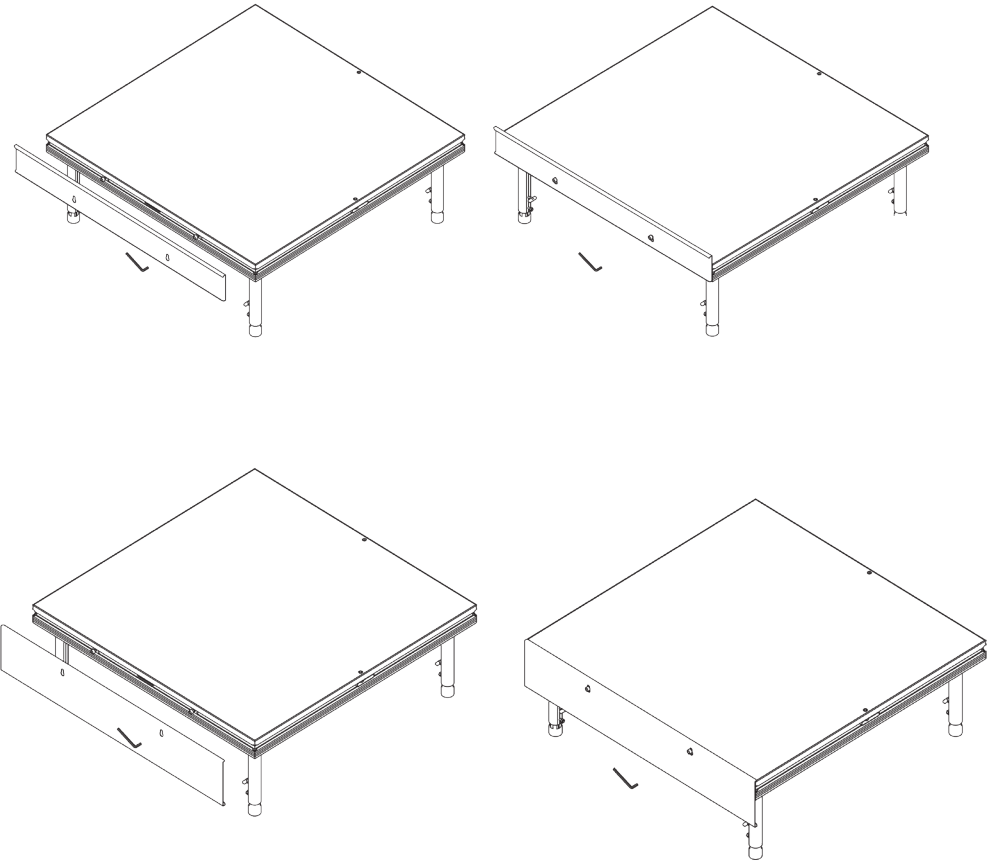

1. Align single assembly inserts with openings on chair stops.

2. Attach chair stops to the single assembly inserts and tighten in place using hex key as shown in Figure M.

Attaching Stairs

Components Needed



Stairs



Single Assembly Insert



Stair Adapter



Hex Key

1. Slide single assembly inserts into the channel in the frame of the platform as shown in Figure N.

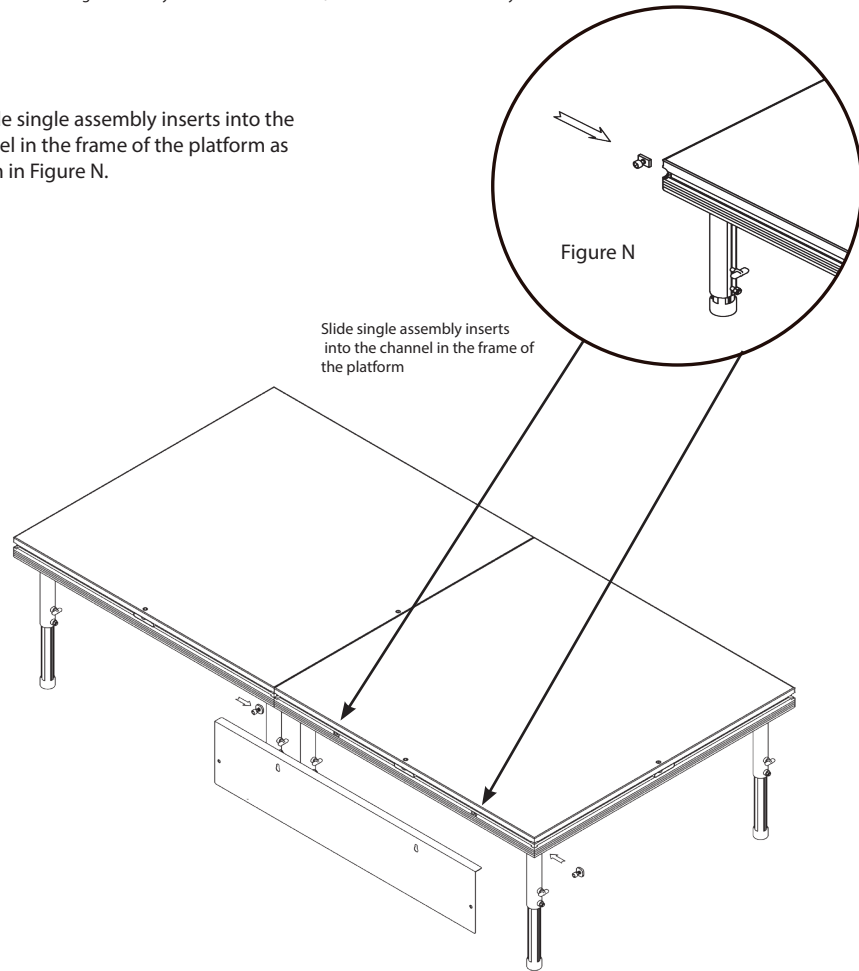

Attaching Stairs

2. Align single assembly inserts with opening on stair adapter, attach stair adapter to single assembly inserts on platform and fasten using hex key as shown in figure O.

Figure O

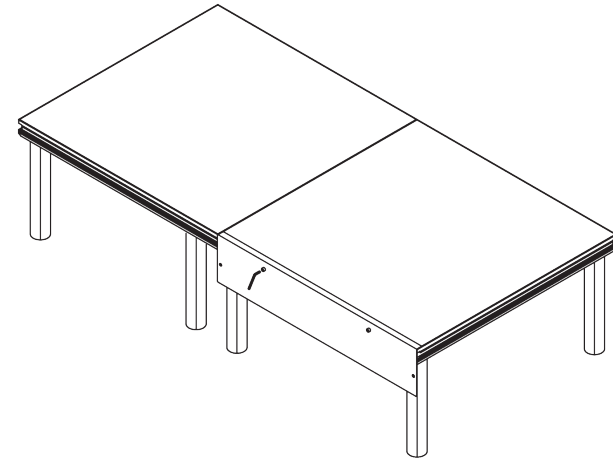

3. Attach stairs to stair adapter with hardware and tighten in place using hex key as shown in figure P.

Figure P

