

VERISMO™ IP

PROFILE RGBALC



Blizzard Lighting, LLC
<http://www.blizzardpro.com>
Waukesha, WI USA
Copyright (c) 2024

TABLE OF CONTENTS

1. Getting Started	3
What's In The Box?	3
Getting It Out Of the Box	3
Powering Up!	3
Getting A Hold Of Us	3
Safety Instructions	4
2. Meet the Verismo™ IP Profile RGBALC	5
Main Features	5
DMX Quick Reference	5
Verismo™ IP Profile RGBALC Pin-Up Picture	6
The Rear Connections	6
3. Setup	7
Fuse Replacement	7
Connecting A Bunch of Verismo™ IP Profile Fixtures	7
Data/DMX Cabling	7
Cable Connectors	8
Take It To The Next Level: Setting Up DMX Control	8
Lens Barrels & Focusing	8
Insert the Gobo Holder	9
Rotating the Shutter Barrel	9
Mounting & Rigging	9
4. Operating Adjustments	10
The Control Panel	10
Control Panel Menu Structure	11
Static Mode	12
Dimming Curves	12
Dimming Speed	12
Dimming Frequency	13
DMX Values In-Depth	13
5. Appendix	14
Keeping Your Verismo™ IP Profile As Good As New	14
Returns (Gasp!)	14
Shipping Issues	14
Tech Specs!	15

1. GETTING STARTED

What's In The Box?

- Verismo™ IP Profile RGBALC Engine
- Power Cable
- Gobo Holder
- This Lovely User Manual

Optional Accessories *(sold separately)*

The following accessories are available for this fixture. But the lone wolves that they are, they must be purchased separately. Contact your authorized Blizzard Lighting dealer for pricing.

- Verismo-LENS-19: Verismo Profile 19° Lens
- Verismo-LENS-26: Verismo Profile 26° Lens
- Verismo-LENS-36: Verismo Profile 36° Lens
- Verismo-LENS-50: Verismo Profile 50° Lens

Getting It Out Of the Box

Congratulations on purchasing the Verismo™ IP Profile RGBALC. Now that you've got your fixture, you should carefully unpack the box and check the contents to ensure that all parts are present and in good condition. If anything looks as if it has been damaged in transit, notify the shipper immediately and keep the packing material for inspection. Again, please save the carton and all packing materials. If a fixture must be returned to the factory, it is important that the fixture be returned in the original factory box and packing.

Powering Up!

All fixtures must be powered directly off a switched circuit and **cannot be run off a rheostat (variable resistor) or dimmer circuit, even if the rheostat or dimmer channel is used solely for a 0% to 100% switch.**

Warning! All fixtures must be connected to circuits with a suitable Ground (Earthing).

Getting A Hold Of Us

If something happens to go wrong, visit blizzardpro.com/support and open a support ticket. We'll be happy to help, honest.

Disclaimer: The information contained in this document are subject to change without notice. Blizzard Lighting™ assumes no responsibility or liability for any errors or omissions that may appear in this user manual. We reserve the right to update the existing, or create a new document to correct any errors or omissions at any time. You can download the latest version of this document from www.blizzardpro.com.

Author:	Date:	Last Edited:	Date:
J. Thomas	3/8/2023	J. Thomas	1/29/2024

Safety Instructions



Please read these instructions carefully. They include important information about the installation, usage and maintenance of this product.

- Please keep this User Guide for future use. If you sell the unit to someone else, be sure that they also receive this User Guide.
- ALWAYS make sure that you are connecting to the proper voltage, and that the line voltage you are connecting to is not higher than that stated on the decal or rear panel of the fixture.
- Make sure there are no flammable materials close to the unit while operating.
- The unit must be installed in a location with adequate ventilation, at least 20in (50cm) from adjacent surfaces. Be sure that no ventilation slots are blocked.
- ALWAYS disconnect from the power source before servicing or replacing fuse and be sure to replace with same fuse size and type.
- ALWAYS secure fixture using a safety chain. NEVER carry the fixture by its head. Use its carrying handles.
- DO NOT operate at ambient temperatures higher than 104°F (40°C).
- In the event of a serious operating problem, stop using the unit immediately. NEVER try to repair the unit by yourself. Repairs carried out by unskilled people can lead to damage or malfunction. Please contact the nearest authorized technical assistance center. Always use the same type spare parts.
- NEVER connect the device to a dimmer pack.
- Make sure the power cord is never crimped or damaged.
- Never disconnect the power cord by pulling or tugging on the cord.
- Avoid direct eye exposure to the light source while it is on.

Caution! There are no user serviceable parts inside the unit. Do not open the housing or attempt any repairs yourself. In the unlikely event your unit may require service, please open a support ticket at www.blizzardpro.com/support.

2. MEET THE VERISMO™ IP PROFILE RGBALC

Main Features

- Light source: 300W RGBALC LED module
- 19°, 26°, 36°, and 50° lens tubes are available (sold separately)
- 16-bit dimming, with 4 user-selectable dimming curves
- User selectable dimming speeds (low/medium/high)
- CCT range and presets from 2200K-10000K
- HSIC (hue, saturation, intensity, color temperature) control
- 4x manual framing shutters & manual focus
- 1-25Hz strobe effects
- Flicker-free resolution, perfect for video
- Gobo/pattern holder (B sized gobos)
- IP Rating: IP65
- Aluminum housing (black)
- PowerCON® TRUE1™ compatible in/out power connectors
- 5-pin male/female XLR input & output connections

Control

- Control system: STM32 control chip, DMX-512
- 7/8/9/10/17-channels (7/8-channel modes offer HSIC color mixing)
- Easy-to-use 4-button control panel with OLED display
- Operating modes: DMX-512, standalone

DMX Quick Reference (7/8/9/10/17-Channel Mode)

7CH	8CH	9CH	10CH	17CH	What It Does
1	1	1	1	1	Master dimmer
--	2	--	--	2	Master dimmer (fine)
--	--	2	2	3	Red
--	--	--	--	4	Red (fine)
--	--	3	3	5	Green
--	--	--	--	6	Green (fine)
--	--	4	4	7	Blue
--	--	--	--	8	Blue (fine)
--	--	5	5	9	Amber
--	--	--	--	10	Amber (fine)
--	--	6	6	11	Cyan
--	--	--	--	12	Cyan (fine)
--	--	7	7	13	Lime
--	--	--	--	14	Lime (fine)
2	3	--	--	--	Hue
3	4	--	--	--	Hue (fine)
4	5	--	--	--	Saturation
5	6	8	8	15	CCT
6	7	9	9	16	Strobe (slow <--> fast)
7	8	--	10	17	Dimming Speed

Verismo™ IP Profile RGBALC Pin-Up Picture



The Rear Connections

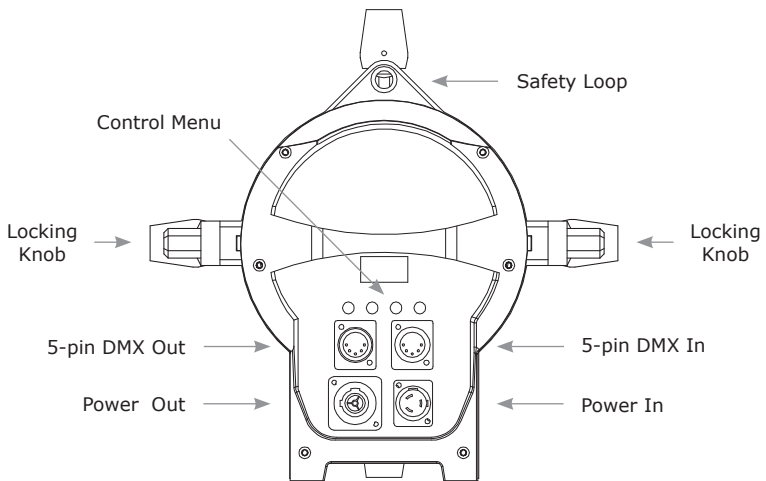

3. SETUP



Before replacing the fuse, disconnect the power cord.
ALWAYS replace it with the same type and rating.

Fuse Replacement

Verismo™ IP Profile fixtures utilize a high-output switch-mode power supply with an internal fuse. Under normal operating conditions, the fuse should not require replacement. The fuse is field replaceable, however it is an advanced procedure suited to qualified individuals. Should the fuse require replacement, please contact Blizzard Lighting for instructions, or to return your unit for service.

Connecting A Bunch of Verismo™ IP Profile Fixtures

You can use a serial data link to run light shows when using a DMX-512 controller with two or more fixtures. The combined number of channels required by all the fixtures on a serial data link determines the number of fixtures the data link can support.

Fixtures on a serial data link must be daisy chained in one single line. Also, connecting more than 32 fixtures on one serial data link without the use of a DMX optically-isolated splitter may result in deterioration of the digital DMX signal. The maximum recommended cable-run distance is 500 meters (1640 ft). The maximum recommended number of fixtures on a serial data link is 32 fixtures.

Data/DMX Cabling

To link fixtures together you'll need data cables. You should use data-grade cables that can carry a high quality signal and are less prone to electromagnetic interference.

For instance, Belden© 9841 meets the specifications for EIA RS-485 applications. Standard microphone cables will "probably" be OK, but note that they cannot transmit DMX data as reliably over long distances. The cable should have the following characteristics:

- 2-conductor twisted pair plus a shield
- Maximum capacitance between conductors – 30 pF/ft.
- Maximum capacitance between conductor & shield – 55 pF/ft.
- Maximum resistance of 20 ohms / 1000 ft.
- Nominal impedance 100 – 140 ohms

Cable Connectors

Cables must have a male XLR connector on one end and a female XLR connector on the other end. This fixture offers both 3-pin and 5-pin connections.

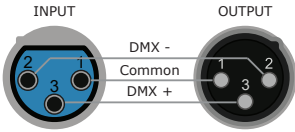

A Word on Termination:

DMX is a resilient communication protocol, however errors still occasionally occur. Termination reduces signal errors, and therefore best practices include use of a terminator in all circumstances. If you are experiencing problems with erratic fixture behavior, especially over long signal cable runs, a terminator may help improve performance.

Take It To The Next Level: Setting Up DMX Control

Step 1: Connect the male connector of the DMX cable to the female connector (output) on the controller.

Step 2: Connect the female connector of the DMX cable to the first fixture's male connector (input).

Note: It doesn't matter which fixture address is the first one connected. We recommend connecting the fixtures in terms of their proximity to the controller, rather than connecting the lowest fixture number first, and so on.

Step 3: Connect other fixtures in the chain from output to input. You should place a DMX terminator on the output of the final fixture to ensure best communication.

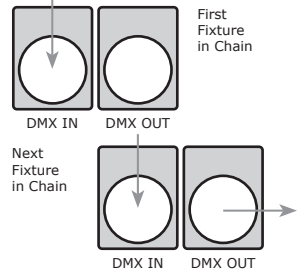

Lens Barrels & Focusing

- 1.) Align and insert a lens tube (sold separately) into the shutter barrel.
- 2.) Install the top focus knob.
- 3.) Install the bottom focus knob.
- 4.) When in use, slide the lens barrel in/out to achieve proper focus, and tighten the focus knobs to secure the lens.

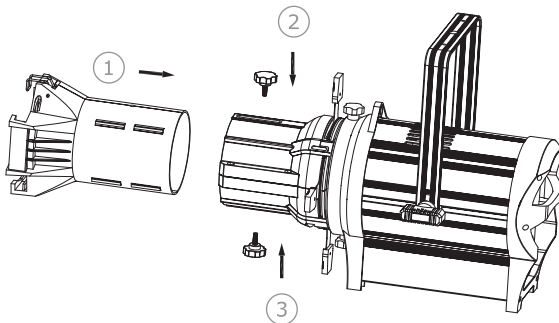

Insert the Gobo Holder

The gobo holder slot is on the top side of the shutter barrel and in front of the shutters. It can accommodate standard B sized gobos, with a recommended image size of 40mm.

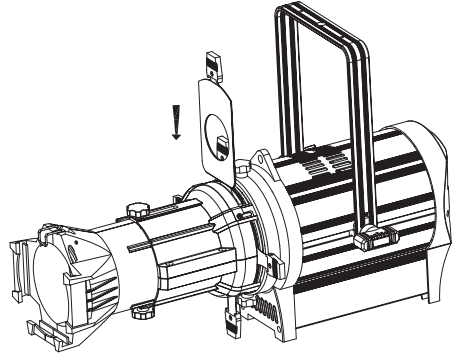
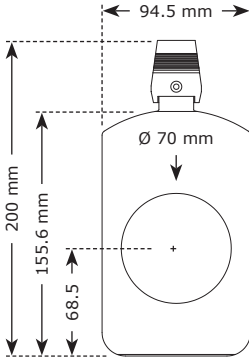

Rotating the Shutter Barrel

- 1.) Loosen the upper and lower barrel rotation knobs located directly behind the shutters. Do not remove the barrel rotation knobs.
- 2.) Rotate the barrel to the desired position (it can rotate up to 34° in either direction from the centered position).
- 3.) Once the barrel is positioned, tighten the barrel's rotation knobs to lock it in place.

Mounting & Rigging

This fixture may be mounted in any SAFE position provided there is enough room for ventilation. The fan or vent pathway must never be obstructed.

Mount the fixture using a suitable "C" or "O" type clamp. The clamp should be rated to hold at least 10x the fixture's weight to ensure structural stability. Do not mount to surfaces of unknown strength, and ensure properly rated rigging is used when mounting fixtures overhead.

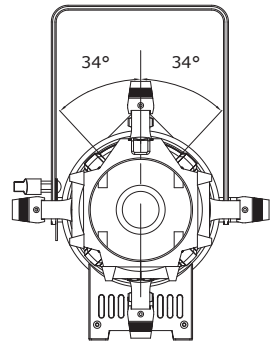

IMPORTANT: Regardless of the rigging option you choose for your fixtures, always be sure to secure your fixture with a safety cable.

4. OPERATING ADJUSTMENTS

The Control Panel

All the features and different modes possible with the Verismo™ IP Profile are accessed by using the control panel on the rear of the fixture. There are 4 control buttons under to the menu display which allow you to navigate through the various control panel menus.

<MENU>

Is used to navigate to the previous higher-level menu item.

<UP>

Scrolls through menu items and numbers in ascending order.

<DOWN>

Scrolls through menu items and numbers in descending order.

<ENTER>

Is used to select and confirm/store the current selection.

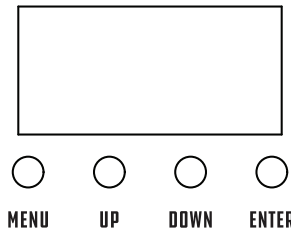

The control panel display shows the menu items you select from the menu map on page #11. When a menu function is selected, the display will show immediately the first available option for the selected menu function. To select a menu item, press **<ENTER>**.

Use the **<UP>** and **<DOWN>** buttons to navigate the menu options. Press the **<ENTER>** button to select the menu function currently displayed, or to enable a menu option. To return to the previous option or menu without changing the value, press the **<MENU>** button.

Control Panel Menu Structure

DMX	Address	Set the starting address (1-512)	
	Control Mode	7H-CH	HSIC modes
		8H-CH	
		9-CH	
		10-CH	
		17-CH	
Static	Red	Red intensity (0% <--> 100%)	
	Green	Green intensity (0% <--> 100%)	
	Blue	Blue intensity (0% <--> 100%)	
	Amber	Amber intensity (0% <--> 100%)	
	Cyan	Cyan intensity (0% <--> 100%)	
	Lime	Lime intensity (0% <--> 100%)	
	Strobe	Strobe (slow <--> fast)	
Personality	Dim Curve	Linear	
		Square law	
		Inv square law	
		S Curve	
	Dim Speed	Off	
		Low	
		Medium	
		High	
	Frequency	1000Hz	
		1200Hz	
		1500Hz	
		2000Hz	
		4000Hz	
		8000Hz	
Fan Mode	Full		
	Auto		
	Silent		
DMX Fail	Hold	Hold or blackout if the DMX signal is lost.	
	Blackout		
Info	Version	Shows current firmware version	
	RDM UID	Unique RDM ID	
	Usage Time	Power on	Total running hrs.
		LED total	LED running hrs.
	Temperature	Celsius (°C)	
Fahrenheit (°F)			
Reset	Yes/No	Load factory defaults	

DMX Mode

Allows the unit to be controlled by any universal DMX controller.

Select the Channel Mode

- 1.) Navigate the menu to reach **DMX**, and press **<ENTER>**.
- 2.) Use the **<UP/DOWN>** buttons to select **Control Mode**, then **<ENTER>**.
- 3.) Then use the **<UP/DOWN>** buttons to select **7H-CH**, **8H-CH**, **9-CH**, **CH-10**, or **CH-17**, and press **<ENTER>** to confirm.

Select the Starting DMX Address

- 1.) Navigate the menu to reach **DMX**, and press **<ENTER>**.
- 2.) Use the **<UP/DOWN>** buttons to select **Address**, then **<ENTER>**.
- 3.) Then use the **<UP/DOWN>** buttons to select a value from 1-512, and press **<ENTER>** to confirm.

Static Mode

- 1.) Navigate the menu to reach **Static**, and press **<ENTER>**.
- 2.) Use the **<UP/DOWN>** buttons highlight **Red**, **Green**, **Blue**, **Amber**, **Cyan**, **Lime**, or **Strobe**, and press **<ENTER>**.
- 3.) The **Dimmer** values will increase/decrease the brightness from 0% to 100%, and **Strobe** values will change the effect (from slow to fast).

Dimming Curves

- 1.) Navigate the menu to reach **Personality**, and press **<ENTER>**.
- 2.) Use **<UP/DOWN>** to highlight **Dim Curve**, and press **<ENTER>**.
- 3.) Then use the **<UP/DOWN>** buttons to select **Linear**, **Square Law**, **Inv Square Law**, **Inv Square Law**, or **S Curve**, and press **<ENTER>**.

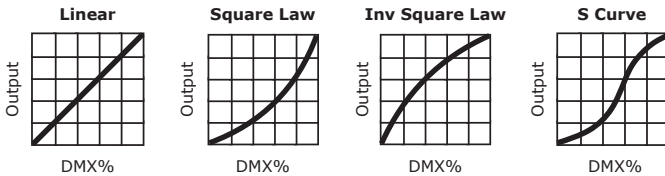

Note: Smoother (and slower) dimming capabilities can be achieved with use of the 4 available dimming curve settings.

Dimming Speed

Allows you to set a fade speed of either *Low*, *Medium*, or *High*. This can help simulate fade speeds of incandescent lamps.

- 1.) Navigate the menu to reach **Personality**, and press **<ENTER>**.
- 2.) Use the **<UP/DOWN>** buttons to select **Dim Speed**. Press **<ENTER>**.
- 3.) Then use the **<UP/DOWN>** buttons highlight **Off**, **Low**, **Medium**, or **High**, then press the **<ENTER>** button.

Dimming Frequency

- 1.) Navigate the menu to reach **Personality**, and press **<ENTER>**.
- 2.) Use the **<UP/DOWN>** buttons to select **Frequency**, then **<ENTER>**.
- 3.) Then use the **<UP/DOWN>** buttons to select a dimming frequency ranging from **1000Hz-8000Hz**, and press **<ENTER>** to confirm.

DMX Quick Reference (7/8/9/10/17-Channel Modes)

7CH	8CH	9CH	10CH	17CH	Value	What It Does
1	1	1	1	1	000 <-> 255	Master dimmer
--	2	--	--	2	000 <-> 255	Master dimmer (fine)
--	--	2	2	3	000 <-> 255	Red
--	--	--	--	4	000 <-> 255	Red (fine)
--	--	3	3	5	000 <-> 255	Green
--	--	--	--	6	000 <-> 255	Green (fine)
--	--	4	4	7	000 <-> 255	Blue
--	--	--	--	8	000 <-> 255	Blue (fine)
--	--	5	5	9	000 <-> 255	Amber
--	--	--	--	10	000 <-> 255	Amber (fine)
--	--	6	6	11	000 <-> 255	Cyan
--	--	--	--	12	000 <-> 255	Cyan (fine)
--	--	7	7	13	000 <-> 255	Lime
--	--	--	--	14	000 <-> 255	Lime (fine)
2	3	--	--	--	000 <-> 255	Hue
3	4	--	--	--	000 <-> 255	Hue (fine)
4	5	--	--	--	000 <-> 255	Saturation
5	6	8	8	15	001 <-> 096 097 <-> 098 099 <-> 112 113 <-> 114 115 <-> 126 127 <-> 129 130 <-> 169 170 <-> 171 172 <-> 218 219 <-> 220 221 <-> 226 227 <-> 228 229 <-> 254 255	CCT 2200K <-> 2800K 2800K 2800K <-> 3000K 3000K 3000K <-> 3200K 3200K 3200K <-> 4000K 4000K 4000K <-> 5600K 5600K 5600K <-> 6000K 6000K 6000K <-> 10000K 10000K
6	7	9	9	16	000 <-> 255	Strobe Strobe (slow <-> fast)
7	8	--	10	17	000 <-> 030 031 <-> 060 061 <-> 090 091 <-> 255	Dimming Speed No Function Low Medium High

5. APPENDIX

Keeping Your Verismo™ IP Profile As Good As New

The fixture you've received is a rugged, tough piece of pro lighting equipment, and as long as you take care of it, it will take care of you. That said, you'll need to take care of it if you want it to operate as designed. You should keep the fixture clean, especially if you are using it in an environment with a lot of dust, fog, haze, wild animals, wild teenagers or spilled drinks.

Cleaning the optics routinely with a suitable glass cleaner will greatly improve the quality of light output. Keeping the fans free of dust and debris will keep the fixture running cool and prevent damage from overheating.

In transit, keep the fixtures in cases. You wouldn't throw a prized guitar, drumset, or other piece of expensive gear into a gear trailer without a case, and similarly, you shouldn't even think about doing it with your shiny new light fixtures.

Common sense and taking care of your fixtures will be the single biggest thing you can do to keep them running at peak performance and let you worry about designing a great light show, putting on a great concert, or maximizing your client's satisfaction and "wow factor." That's what it's all about, after all!

Returns (Gasp!)

We've taken a lot of precautions to make sure you never even have to worry about sending a defective unit back, or sending a unit in for service. But, like any complex piece of equipment designed and built by humans, once in a while, something doesn't go as planned. If you find yourself with a fixture that isn't behaving like a good little fixture should, you'll need to obtain a Return Authorization (RA).

Don't worry, this is easy. Just visit www.blizzardpro.com/support and open a support ticket, and we'll issue you an RA. Then, you'll need to send the unit to us using a trackable, pre-paid freight method. We suggest using USPS Priority or UPS. Make sure you carefully pack the fixture for transit, and whenever possible, use the original box & packing for shipping.

When returning your fixture for service, be sure to include the following:

- 1.) Your contact information (Name, Address, Phone Number, Email address).
- 2.) The RA# issued to you
- 3.) A brief description of the problem/symptoms.

We will, at our discretion, repair or replace the fixture. Please remember that any shipping damage which occurs in transit to us is the customer's responsibility, so pack it well!

Shipping Issues

Damage incurred in shipping is the responsibility of the shipper, and must be reported to the carrier immediately upon receipt of the items. Claims must be made within seven (7) days of receipt.

Tech Specs!

Weight & Dimensions						
Dimensions	25.6" x 12.6" x 18" (649 x 320 x 458 mm)					
Weight (engine only)	21.2 lbs. (9.6 kg)					
Power						
Operating Voltage	100-240VAC, 50-60 Hz					
Power	289W 2.56A, PF: .99					
Light Source						
LED	300W RGBALC LED module, 50,000+ hour lifetime					
Optical						
Luminous Intensity	19° Lens: 10,229 Lux @ 2.5M, 2,483 Lux 5M					
	26° Lens: 5,032 Lux @ 2.5M, 1,289 Lux 5M					
	36° Lens: 3,043 Lux @ 2.5M, 791 Lux 5M					
	50° Lens: 1,481 Lux @ 2.5M, 330 Lux 5M					
Gobo Size	B (86mm outer, 40mm image)					
Noise Level						
Measured at 1m distance from the 4 sides and level with centerline.	Fan Mode	Front	Back	Left	Right	Average
	Full	45.1	40.8	43.4	42.4	42.925
	Auto	38.1	33.8	35.7	35.5	35.775
	Silent	38.1	33.7	35.6	35.6	35.75
Control						
Protocol	USITT DMX-512					
DMX Channels	7/8/9/10/17-channel					
Input/Output	5-pin XLR male/female					
Operating Modes	DMX-512, standalone					
Warranty						
2-year limited warranty, does not cover malfunction caused by damage to LEDs.						

Dimensional Drawings

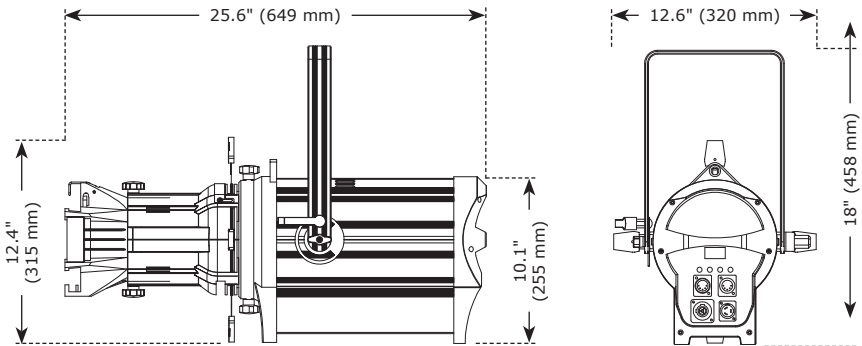



**Enjoy your product!
Our sincerest thanks for your purchase!
--The team @ Blizzard Lighting**